



XB-200 Data Buoy

User Guide

Last Revision: 27 December 2024

Date Generated: 10 January 2025

Copyright © 2025 NexSens Technology, Inc.

Table of Contents

- 1. General** 4
 - XB-200 Data Buoy Overview 4
 - Key Components 4
 - Key Specifications 6
 - CB-Series Data Buoy Planning & Precautions 7
 - Buoy sizing and power budget 7
 - Buoy ballast 7
 - Buoy mooring 7
 - Electrical connections 7
 - Safe deployment 8

- 2. Buoy Setup** 9
 - XB-200 Buoy Assembly 9
 - Instrument Cage Installation 9
 - Solar Tower Installation 10
 - Ballast Weight & Stability 11
 - M550 Beacon for CB-Series Data Buoys 12
 - Installation 12
 - Operation 13
 - Use of Sacrificial Anodes on CB-Series Data Buoys 14
 - NexSens Sacrificial Anodes 14
 - Zinc as Anode Material 14
 - CB-Series Data Buoy Instrument Mounts 16
 - Topside Buoy Instrument Mounts 16
 - Subsurface Buoy Instrument Mounts 16

- 3. Deployment** 18
 - CB-Series Data Buoy Ballast Weight & Stability 18
 - Top-Side Weight 19
 - Ballast Weight 20
 - Buoy Ballast Weights 21
 - Mooring NexSens Data Buoy Platforms 22
 - Buoy Ballast 22
 - Mooring Eye Lifting 22
 - Data Buoy Mooring Types 22
 - CB-Series Data Buoy Deployment Tips 28
 - NexSens CB-Series Data Buoys 28
 - Connecting Mooring Hardware 28
 - Buoy Deployments 29

Single-Point Mooring Buoy Deployments	30
Two-Point and Three-Point Mooring Buoy Deployments	31
Planning a Medium-Deep Water Mooring for Small Data Buoys	32
Medium-Deep Water Deployment Considerations	32
Mooring Hardware Materials	36
Deployment	38
4. Warranty	41
5. Service Request	42
Service Request	42

1. General

XB-200 Data Buoy Overview

The XB-200 data buoy is ideal for applications requiring portability and quick deployment, yet strong enough for rough water. The platform is suited for limnology research, dredge turbidity monitoring, temperature or dissolved oxygen profiling, fisheries and aquaculture monitoring, harmful algal bloom detection, and oil spill response. When configured with the NexSens X3 4G LTE cellular or Iridium satellite data logger, all electronics are mounted under the solar tower top plate for quick access and easy replacement. The buoy is also highly customizable with user-supplied electronics. It supports a wide variety of topside and subsurface sensors and measurement instruments.



Figure 1: XB-200 data buoy.

Key Components

Buoy Hull

The hull is constructed of UV-stabilized, linear low-density polyethylene (LLDPE) and filled with lightweight, closed-cell polyurethane foam to keep the buoy afloat even if pierced or damaged. The buoy provides a net buoyancy of 200 lb (91 kg) and includes a stainless steel instrument cage for ballast weight and sensor mounting, and three 4" pass-through ports to accommodate water monitoring sensors.

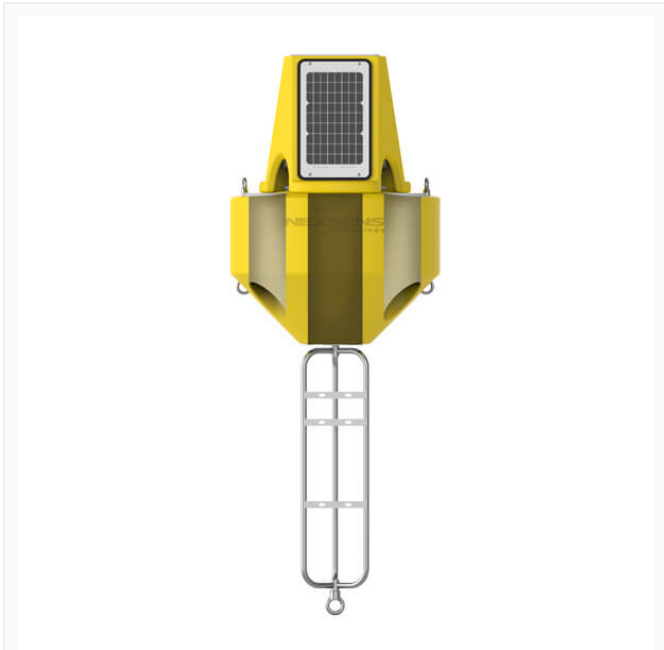

Figure 2: Pass-through ports on XB-200.



Figure 3: Instrument cage on XB-200.

Data Well

Two separate compartments in the data well can house batteries, measurement electronics, or telemetric equipment. The well height is 20.5" (52.1 cm), with a 9.7" (23.6 cm) diameter above the battery compartment.

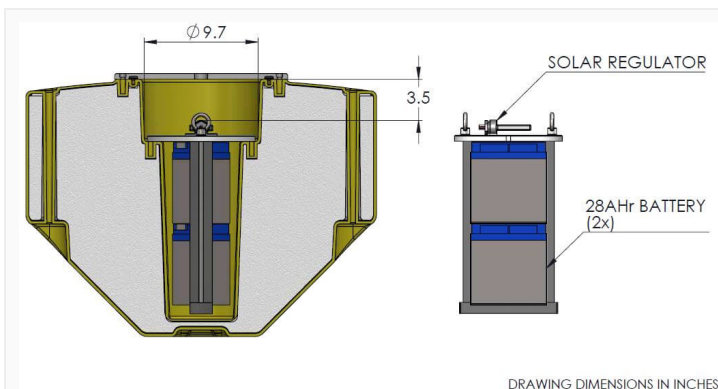

Figure 4: Two 28 Ahr batteries installed.

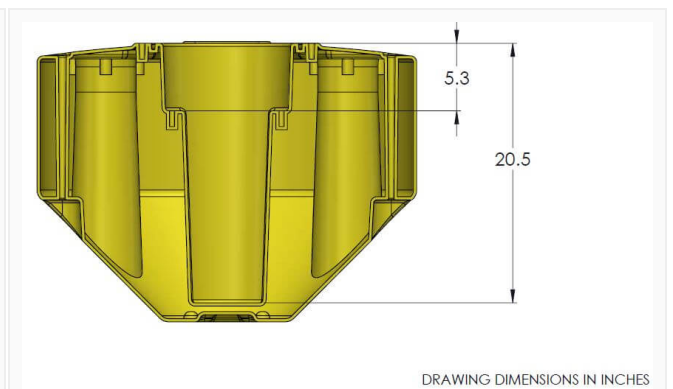

Figure 5: Empty XB-200 battery well.

Solar Tower

The solar tower is also made of LLDPE and contains an array of (3) 15-watt solar panels wired in parallel to provide 45 watts of solar charging. Each solar panel is user-replaceable and contains a 2-pin connector that plugs into the middle solar hub on top of the buoy data well. A top plate made of Starboard marine plastic provides a mounting location for top-side sensors and a NexSens X3 Environmental Data Logger.



Figure 6: XB-200 solar tower.



Figure 7: XB-200 buoy with X3 Environmental Data Logger.

Key Specifications

- **Hull Outer Diameter:** 30.0" (76.2cm)
- **Hull Height:** 22.0" (55.8cm)
- **Battery Well Inner Diameter:** 9.7" (23.6cm) above battery
- **Battery Well Height:** 20.5" (52.1cm)
- **Pass-Through Hole Diameter:** 4.0" (10.2cm)
- **Tower Height:** 20.0" (50.8cm)
- **Solar Panels:** 3x 15-watts
- **Weight:** 67 lb. (30.4kg)
- **Net Buoyancy:** 200 lb. (91kg)
- **Hull Material:** UV stabilized, linear low-density polyethylene (LLDPE) with closed-cell polyurethane foam fill
- **Hardware Material:** 316 stainless steel
- **Mooring Attachments:** 2x 5/8" eye nuts

CB-Series Data Buoy Planning & Precautions

Buoy deployments are usually complex operations that involve many elements including sensors, data loggers, mounting hardware, and mooring equipment. Careful planning and precautions are essential to the success of a buoy project, not only for system operation and data collection but also to ensure the safety of project personnel and minimize the risk of damage to expensive system components. When planning a buoy deployment, be sure to give careful consideration to the following aspects:

Buoy sizing and power budget

Buoys come in various physical sizes with differing battery and solar charge capacities. A buoy must be adequately sized to tolerate the site environmental conditions while providing sufficient power for continuous system operation. A *power budget* should be analyzed to ensure the system can meet the demand for sensor measurements and data transmission.

Buoy ballast

Proper ballast of a buoy is critical to buoy stability when it is deployed in the water. Be sure to review the *ballast weight and stability guide* when designing a buoy system. Some experimentation may be required before final deployment.

Buoy mooring

Mooring systems come in many forms depending on the location, water depth, and environmental conditions to which a buoy will be exposed. As a starting point, the *mooring data buoys guide* provides an overview of common mooring strategies. However, NexSens does not endorse any particular mooring strategy, and systems should be designed and executed based on careful consideration and local knowledge of the deployment site.

Electrical connections

Many NexSens buoy systems utilize UW connectors for connection of power and sensor cables. Data loggers such as the X2-CB have *UW receptacle ports* to receive sensor cables fitted with *UW plug connectors*. UW connectors provide a double O-ring seal, with one O-ring inside the receptacle and one around the plug. In order to ensure waterproof connection, check the following each time a UW connection is made:

1. The O-ring inside the receptacle is present (has not fallen out)
2. The receptacle and plug are clean, dry and free of debris
3. The O-ring on the plug is lightly greased
4. Connection is tight, secure and fully seated
5. Unused receptacle ports are fitted with *UW port plugs*

Connections may be periodically inspected and maintained with O-ring grease, at a minimum before each buoy deployment.

CB-Series data buoys contain a waterproof data well constructed of stainless steel where batteries are mounted. Whenever installing or maintaining battery systems, use caution to

avoid short-circuiting of battery poles to the metal walls of the data well. Gloves and tools with rubber grips are recommended, and any exposed connections should always be covered with electrical tape or other suitable coverings.

Safe deployment

Above all else, safety is the most critical consideration to take during the planning and precautions of a buoy deployment. Any time a buoy system is deployed, there are countless hazards, including, but not limited to, working on/near water and lifting of heavy equipment. Important factors to consider for personnel safety are:

- Use of safety equipment (i.e., life jackets, gloves, steel toed boots, etc.,)
- Proper lifting and mooring techniques
- Awareness of on-site and surrounding weather conditions and advisories

Despite careful planning and precautions, unforeseen situations are always still a possibility. Buoy deployments are an at-risk operation, and the user assumes liability for any injury or damages that may occur.

2. Buoy Setup

XB-200 Buoy Assembly

The NexSens buoy **instrument cage** attaches to the bottom of the XB-200 data buoy for water sensor deployments, simultaneously lowering the center of gravity and increasing stability. The cage is a critical component of a data buoy's **ballast weight** and provides a mounting location for additional ballast weight as needed. The solar tower contains an array of (3) 15-watt solar panels wired in parallel to provide 45 watts of solar charging. A top plate made of Starboard marine plastic provides a mounting location for top-side sensors.

Instrument Cage Installation

1. Use a 3/4" socket or wrench to remove the (6) pre-installed bolts from the bottom of the buoy.

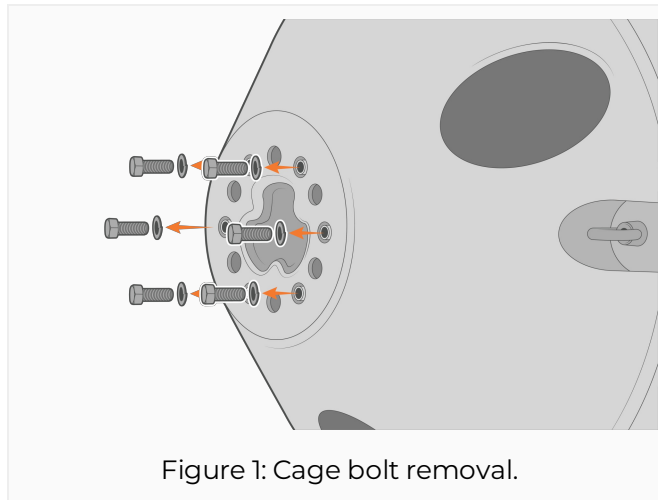

2. Align the included instrument cage with the open bolt holes on the bottom of the buoy. Use a 3/4" socket or wrench to re-install the (6) bolts and tighten the cage to the buoy.
 - a. Ensure to tighten only until the lock washers are flattened.
 - b. Use the "star" or "criss-cross" pattern while installing the cage.

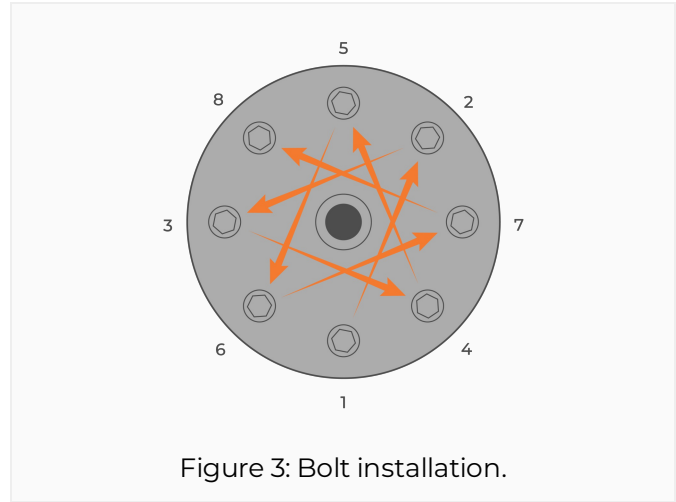
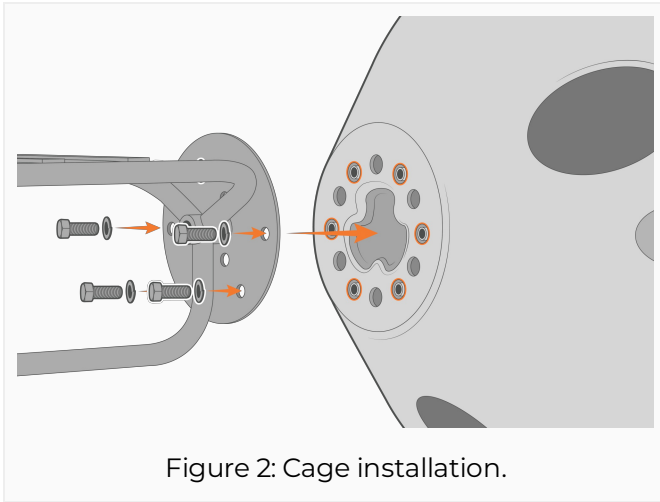

Solar Tower Installation

- Use a 1/2" socket or wrench and the (6) included hex head cap bolts, lock washers, and flat washers to install the solar tower.
 - It is recommended to apply an anti-seize compound to the bottom threads of each bolt before installation.
 - Ensure the solar tower cables are free and not pinched beneath the tower upon installation.

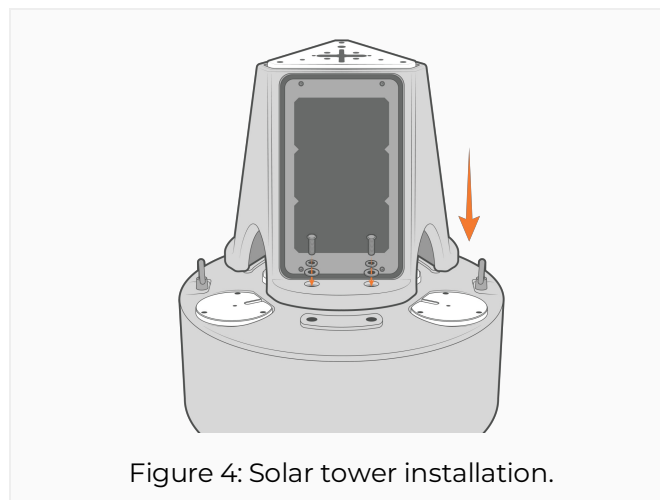

Ballast Weight & Stability

Additional ballast weight may be needed to prevent the overturning of an XB-200 buoy system and ensure its stability in the water. The buoy's center of gravity is near the water surface without instruments connected. Any weight added above the water surface must be appropriately counterbalanced by adding ballast weight below the surface. The buoy data well is not rated for submersion, so proper ballast weight is critical to ensure that the buoy does not overturn, including when the buoy is subjected to additional loading (e.g. high wind/waves, periodic snow/ice loads, etc.).

For more information regarding top-side and ballast weight, follow the link provided:

- [Data Buoy Ballast Weight & Stability](#)

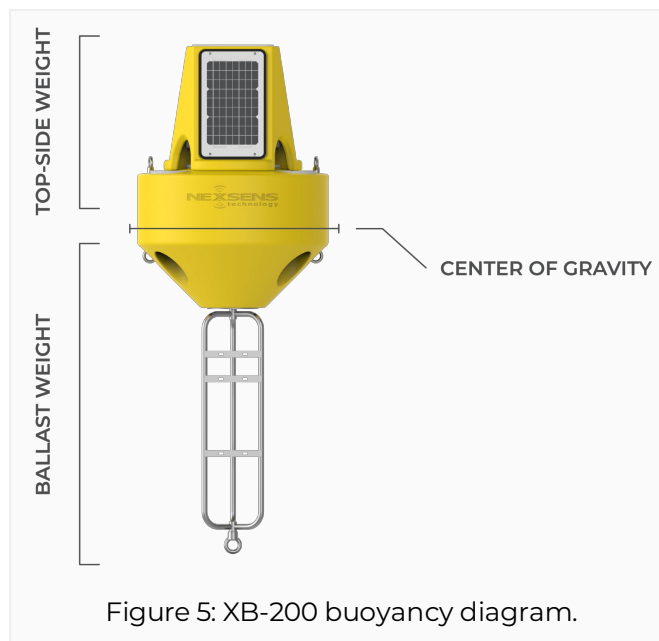

M550 Beacon for CB-Series Data Buoys

The [NexSens M550 Solar Marine Light](#) is a common accessory added to NexSens data buoys up to and including the CB-450. Depending on the configuration, it has a 1-3 nautical mile range and is normally delivered with flange mount hardware, yellow color, and default 15 flash/minute pattern (Model: *M550-F-Y*).



Figure 1: M550 Solar Marine Light.

Installation

While it typically comes pre-installed, the M550 can easily be removed and/or installed by the user. For guidance with the standard flange mount version, refer to the [M550 flange mount installation instructions](#). For guidance with the pole-mounted beacon version, refer to the [M550 pole-mount installation instructions](#).

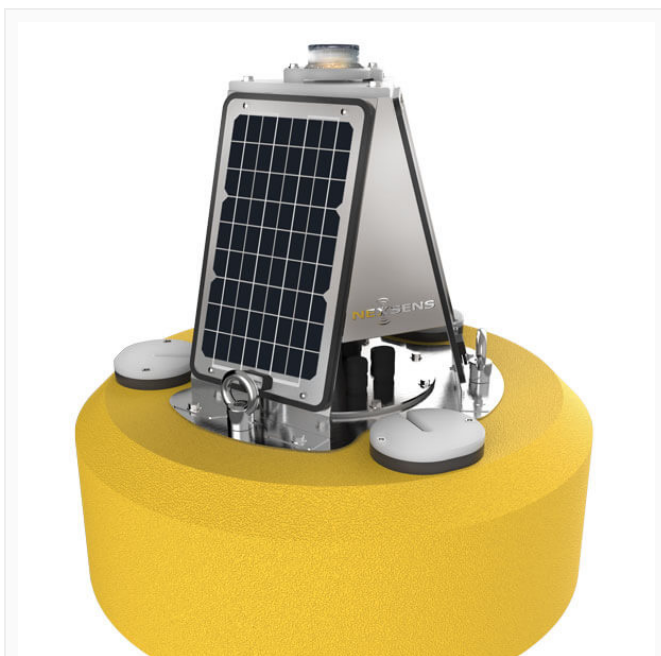

Figure 2: M550 beacon mounted on top of the CB-450 data buoy.



Figure 3: Pole-mounted beacon on the XB-200 data buoy.

Operation

The M550 is controlled using an IR programmer that is normally provided with the beacon.



Figure 4: IR remote

The IR programmer can be used to perform the following functions:

- Turn beacon on and off
- Check the battery pack charge status
- Change the flash pattern
- Change the flash intensity

Use of Sacrificial Anodes on CB-Series Data Buoys

Sacrificial **zinc anodes** are recommended for use on CB-Series data buoys any time they will be used in saltwater environments. This helps to prevent corrosion on the stainless steel frame, as zinc is a more active metal that will be consumed while protecting the stainless steel.

NexSens Sacrificial Anodes

Anodes sourced from NexSens are sized specifically for installation onto buoy frames and instrument cages using a pair of screws provided with the anode. They will typically need to be replaced approximately every 6 months, though this may vary depending on factors such as the temperature and salinity of the saltwater environment. Buoys should be regularly inspected and anodes replaced any time it appears they will be consumed before the next scheduled maintenance. It is often a good idea to have two anodes installed onto a buoy – one on the frame and one on the cage – and replace them intermittently to ensure that there is always sufficient protection for the stainless steel. Anode replacement will require a 4-mm Allen wrench to remove the pair of screws connecting the two anode halves.



Zinc as Anode Material

Zinc is chosen for the anode material because it is a readily-available metal with a **lower reduction potential** (-0.76V) than the steel of the buoy frame. This offers the steel what is known as **cathodic protection**, where oxidation reactions are transferred away from the steel to the zinc when placed in highly ionic environments such as saltwater in the case of a buoy. The zinc is slowly consumed by the process, hence the term sacrificial anode.

In theory, other materials besides zinc can be used as the anode as long as they rank lower on the reduction potential scale than the stainless steel. Generally speaking, the larger the difference between the metals on the scale, the faster the rate of the oxidation-reduction reaction. Materials with lower reduction potential than zinc may therefore be consumed more rapidly and require more frequent changes. Regardless of anode material chosen, frequent inspection and replacement of anodes as needed can extend the life of a data buoy significantly in saltwater.

Sacrificial anodes are normally not necessary for buoys used in freshwater except in special

circumstances. It is therefore generally recommended only to order anodes with buoys intended for use in brackish or saltwater.

CB-Series Data Buoy Instrument Mounts

CB-Series data buoys support a wide range of topside and subsurface instruments with uniquely designed buoy instrument mounts. Mounting accessories are available for many of the most commonly-used sensors and instruments. Click on each accessory name for product information and instructions for use.

Topside Buoy Instrument Mounts

GPS Receiver – Mounts for GPS positioning devices:

- [Garmin GPS 24xd Receiver](#)

Radar Reflector – For passive reflection of radar waves and visibility:

- [CB-Series Buoy Radar Reflector](#)

Weather Sensors – Mounts for many of the most common meteorological sensors deployed on buoys:

- [Airmar WX-Series Weather Sensors](#)
- [Gill MaxiMet Weather Sensors](#)
- [LI-COR Terrestrial Light Sensors](#)
- [Lufft WS-Series Weather Sensors](#)
- [METER ATMOS Weather Sensors](#)
- [Vaisala WXT-Series Weather Sensors](#)

Miscellaneous Mounts – Other mounting brackets:

- [CB-150/CB-250/CB-450 Instrument Offset Mount](#)

Subsurface Buoy Instrument Mounts

Data Logger/Battery Pack Mounts – For mounting of NexSens X2-SDL data logger or SBP500 extra/reserve battery packs to instrument cage:

- [X2-SDL Instrument Cage Mount](#)

Instrument Deployment Pipes – For instrument installation and topside access using buoy pass through ports:

- 912M – 2" diameter for use with CB-150 and CB-250 buoys
- 914M – 4" diameter for use with CB-450 and CB-650 buoys
- 916M – 6" diameter for use with CB-950 buoy
- 918M – 8" diameter for use with CB-1250 buoy

- 918M-PO4 – 8" diameter for use HydroCycle PO4 sensor on CB-1250 buoy

Click for [product information](#) and [instructions for use](#).

Miscellaneous Instrument Mounts – Mounting hardware for some commonly used sensors:

- [Airmar SS510 Sonar Sensor Mount](#)
- [MC-600 Instrument Mooring Clamp](#)
- [Underwater PAR Sensor Mounting Arm](#)
- [YSI EXO Sonde Mooring Clamps](#)

Profiling Instrument Mounts – Mounting brackets for commonly used current meters and profiler (ADCP) instruments:

- [Nortek Aquadopp Buoy Instrument Hole Mount](#) – variants for mounting on CB-950 and CB-1250 buoys
- [Nortek Aquadopp Mooring Cages](#) – variants for Aquadopp current meters and current profilers
- [Nortek Signature1000 ADCP Instrument Cage](#)

A complete list of data buoy accessories is available [here](#).

3. Deployment

CB-Series Data Buoy Ballast Weight & Stability

Ballast weight may be needed to prevent overturning a CB-series buoy system and ensure stability in the water. The center of gravity of NexSens CB-Series buoys is near the water surface *without instruments connected*. Therefore, any top-side weight added above the water's surface (e.g., sensors, sensor mounts) must be appropriately counterbalanced by ballast weight below the surface (e.g., instrument cage, chain, anchors, etc.). Before deploying a buoy system, some experimentation may be required to balance the system properly.

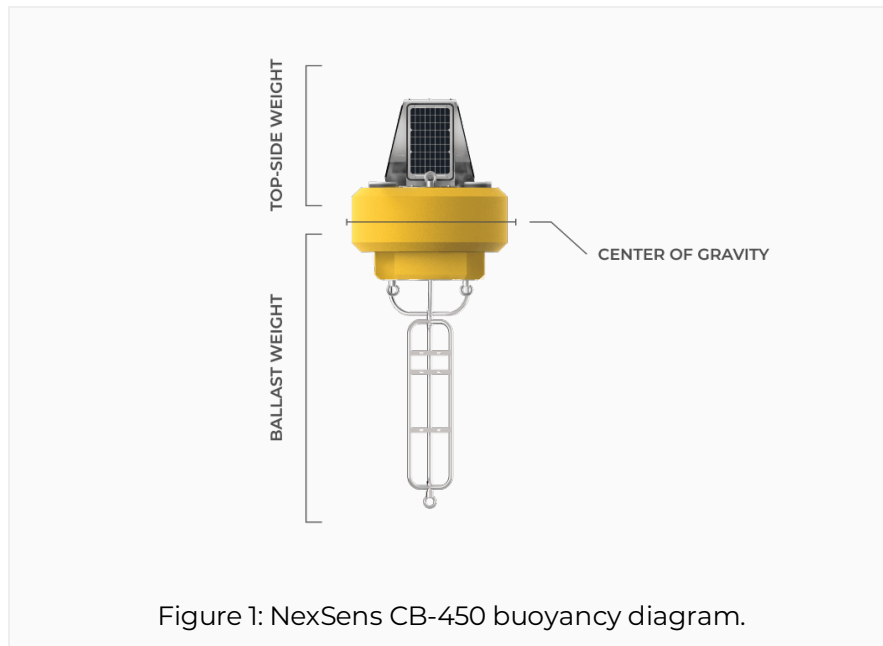

Top-Side Weight

Top-side weight is any weight mounted on the buoy above the water surface or the buoy's center of gravity. Weight located further from the buoy's center of gravity will cause greater instability of the buoy. For example, suppose a weather sensor is mounted 36" above the water surface (*Figure 2*). In that instance, the sensor mount will cause more buoy instability than mounted 24" above the surface (*Figure 3*). As a result, the buoy would require more subsurface ballast weight to counterbalance.

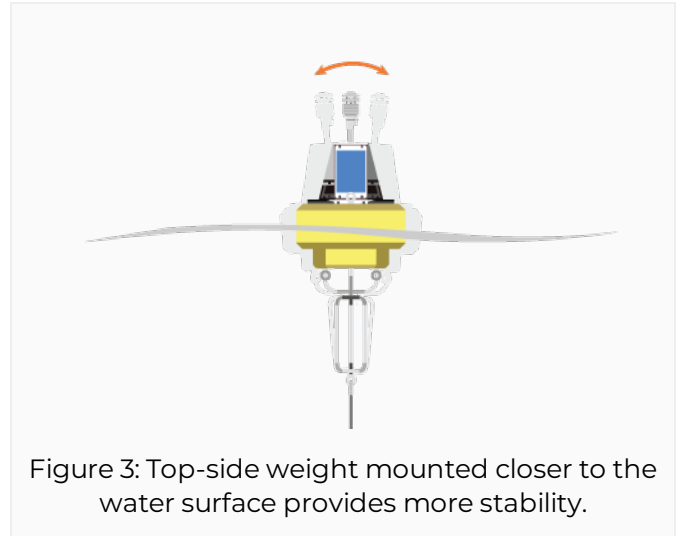
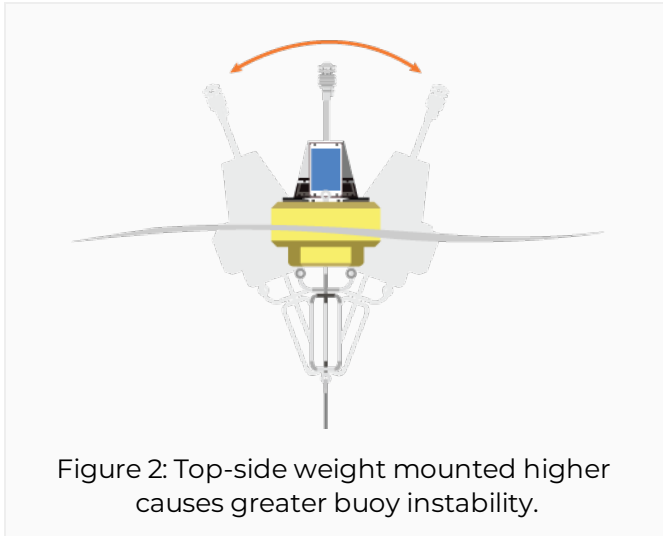

Ballast Weight

Ballast weight is any weight mounted on the buoy below the water surface or the buoy's center of gravity. Contrary to top-side weight, a ballast weight added further below the surface (*Figure 4*) will provide a more significant stabilizing effect than the same size weight mounted closer to the surface (*Figure 5*). An instrument cage mounted to the buoy frame helps stabilize the buoy and provides a deeper location for mounting additional weight. For single-point mooring configurations, mooring chains and lines connected to the bottom of the cage may provide adequate ballast. For multi-point configurations, the mooring hardware does not contribute to the ballast weight. If needed, add ½ inch galvanized chain (~2.3lb/ft) to the bottom of the cage, or utilize [NexSens ballast weights](#) that can be added to the cage in specific applications.

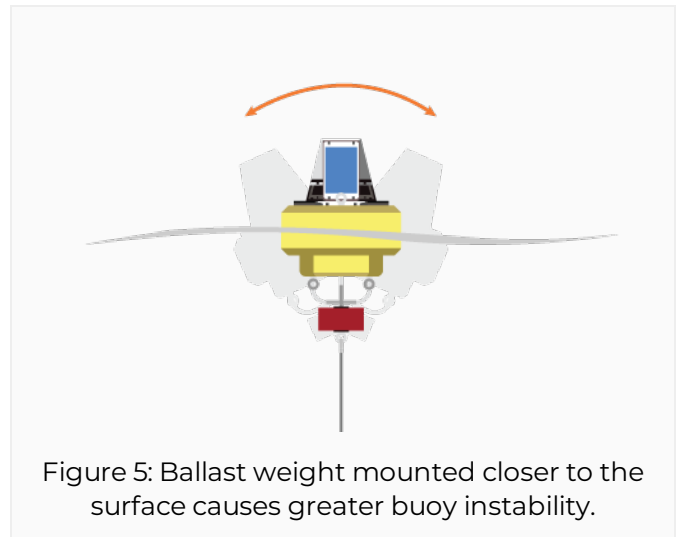
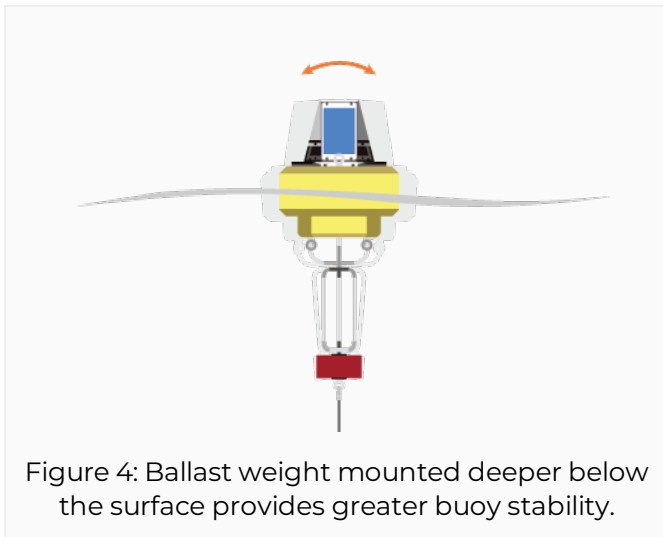

NexSens CB-series buoy data wells are not rated for submersion, so proper ballast weight is critical to ensure that the buoy does not overturn, including when subjected to additional loading (e.g., high wind/waves, periodic snow/ice loads, etc.).

For information on NexSens CB-Series buoy ballast weight recommendations, follow the link below.

[NexSens CB-Series Buoy Ballast Weights](#)

Buoy Ballast Weights

The table below indicates the minimum recommended buoy ballast weights for each CB-Series data buoy, assuming no additional topside weight and calm environmental conditions. Included instrument cages mounted to the buoy frame helps stabilize the buoy and provides a deeper location for mounting additional weight. The small model instrument cage (10 lbs.) is included with the purchase of CB-150, CB-250, & CB-450 buoy models and is an optional purchase for the CB-50. The large model instrument cage (26 lbs.) is included with the purchase of CB-650, CB-950, & CB-1250 buoy models. Typically, no additional ballast weight is necessary for the CB-25-SVS, CB-25, CB-40, CB-75-SVS, & CB-75 models as each buoy comes standard with either 1/2" galvanized chain (CB-25, CB-25-SVS, CB-75, & CB-75-SVS) or an installed steel instrument pipe (CB-40) for ballast.

Model	Buoyancy (lbs.) ¹	Minimum Recommended Ballast Weight (lbs.) ²
CB-25-SVS ³	25	—
CB-25 ³	25	—
CB-40 ³	40	—
CB-50	50	—
CB-75-SVS	75	—
CB-75	75	—
CB-150	150	—
XB-200	200	—
CB-250	250	—
CB-450	450	—
CB-650	650	50
CB-950	950	100
CB-1250	1250	150

¹Net buoyancy is given for the CB-25-SVS to CB-450; Gross buoyancy is given for the CB-650 to CB-1250

²Minimum recommended ballast weight incorporates the weight of the included or optionally purchased [instrument cage](#).

³Discontinued models

Important: To effectively provide adequate ballast weight, a variety of application-specific criteria (sensor weight and positioning, water level fluctuations, wave and current action, external loading, etc.) must be thoroughly reviewed prior to deployment. NexSens does not endorse using these specific buoy ballast weights for all applications.

For more information regarding buoy ballast weight and stability, please refer to the following article:

[CB-Series Data Buoy Ballast Weight & Stability](#)

Mooring NexSens Data Buoy Platforms

This article contains only general information on the available mooring options for NexSens data buoys. Developing an effective mooring strategy requires reviewing various application-specific criteria (water level fluctuations, currents and wave action, debris loads, etc.) before deployment. This document is intended to provide a starting place for mooring design and is by no means comprehensive. Good mooring design is often developed through years of experience with various deployment scenarios. For first-time mooring designers, it is best to include an experienced marine engineer.

NexSens Technology supplies mooring hardware to support user-designed systems but does not endorse any particular mooring strategy for any specific application and does not take responsibility for mooring performance or damage resulting from mooring failure.

Buoy Ballast

Buoy ballast is best handled by adding weight to the bottom of the buoy and not relying on the mooring weight to act as ballast. Additionally, the weight associated with biofouling growth can impact the buoy buoyancy and mooring performance. Minimum recommended ballast weights for NexSens Technology data buoys can be reviewed at the link below.

[NexSens Technology Buoy Ballast Weights](#)

More information on buoy ballast can also be found at the link below.

[CB-Series Data Buoy Ballast Weight & Stability](#)

Mooring Eye Lifting

All NexSens CB-Series buoy models have three topside mooring eyes located around the solar tower. These are sufficiently strong that a buoy can be lifted from a single top-facing eye nut via crane or winch for removal or deployment when required. Care should always be taken to avoid damaging any solar panels, topside sensor mounts and sensors connected to the instrument cage when lifting and moving a buoy.

Data Buoy Mooring Types

There are three commonly used mooring types for data buoy applications:

1. Catenary moorings
2. Semi-taut two point moorings
3. Inverse-catenary (S-shape) moorings

1. Catenary Moorings

For shallow deployments with minimal wind, wave and current loading, most data buoys utilize catenary moorings. Shallow deployments can be designed with all chain or a combination of heavy bottom chain and light water column chain. Deeper water moorings may need to use a combination of chain and rope.

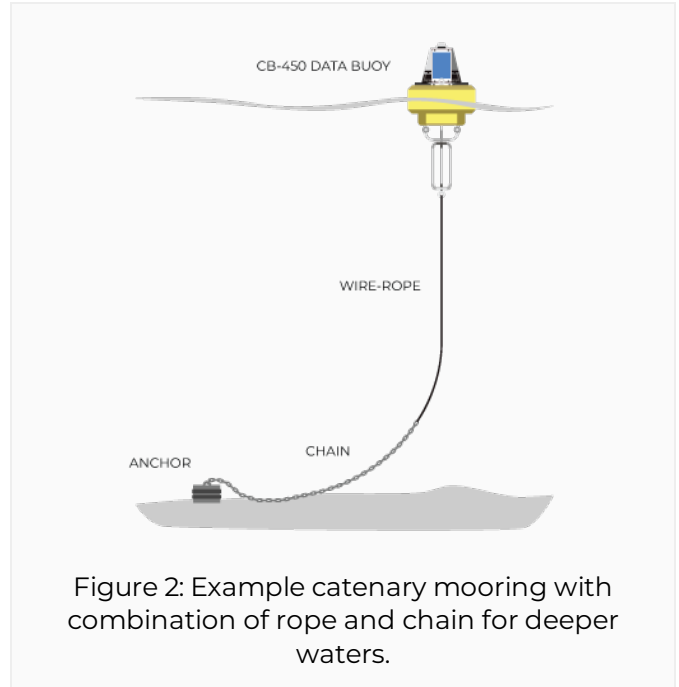
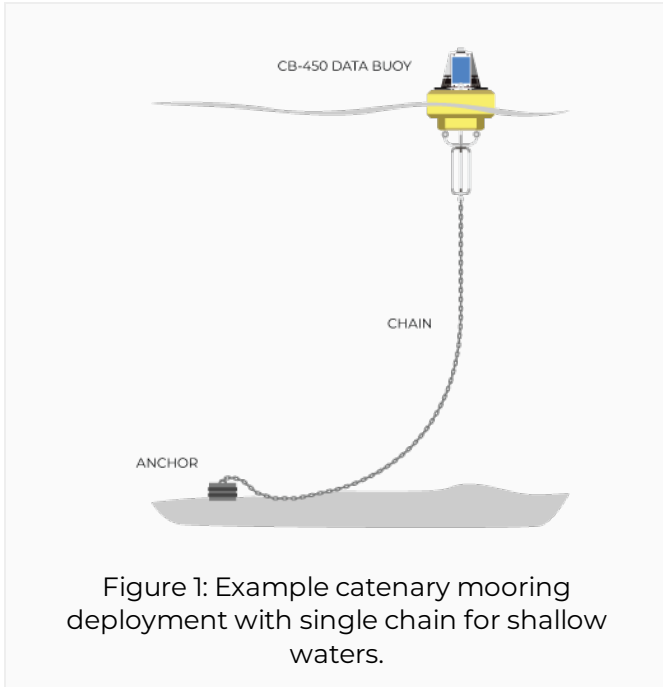

Small-buoy catenary moorings

Additional surface or subsurface floatation may be required for smaller buoyancy buoy applications where the floatation may not be adequate to support the mooring weight. Extra floatation can also free motion for wave measurement applications or offer additional resistance to horizontal loading.

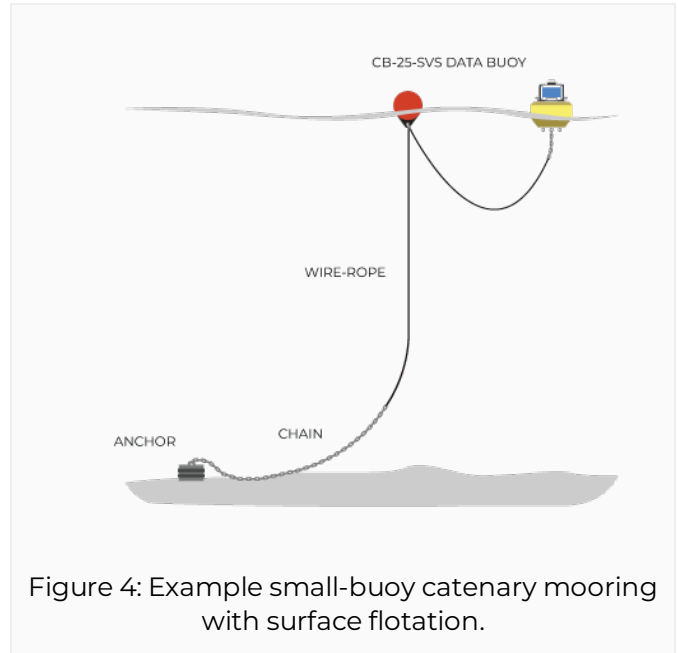
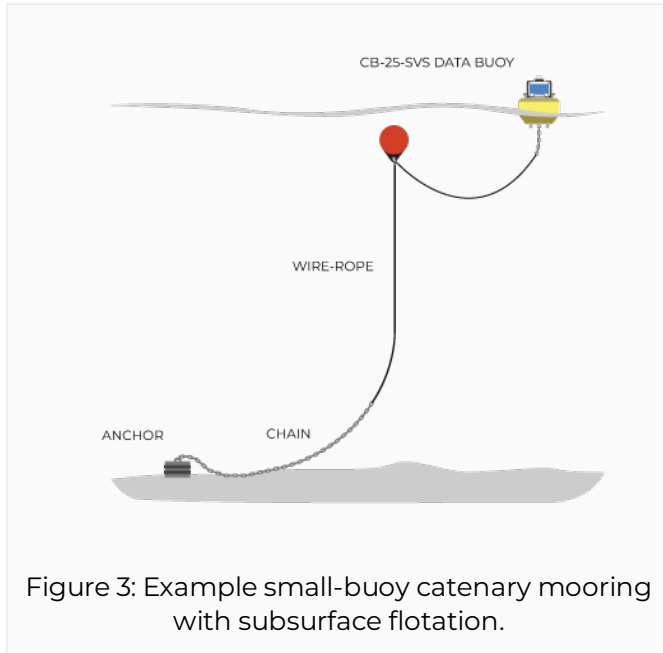

Horizontal Loading

As wind, wave and current loads increase, the buoy is driven away from the anchor and mooring can be pulled taut resulting in the buoy listing to one side. Damage can result with topside equipment and solar panels becoming submerged. Additional surface or subsurface floatation may be required.

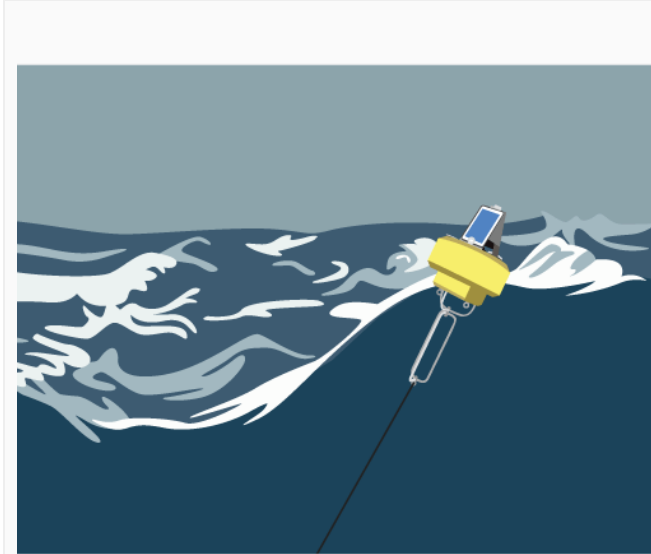

Figure 5: Depiction of horizontal loading resulting in buoy listing to one side.

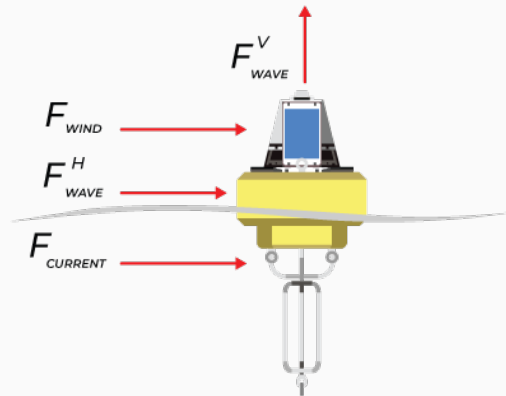

Figure 6: Force diagram representing external forces acting on buoys in natural environments.

2. Semi-taut two point moorings

For calm, shallow water with limited horizontal loading, semi-taut two point moorings can be utilized. These moorings are useful for suspending sensor lines by pulling the mooring lines free and clear. Rough water, shifting bottom or horizontal loads can tangle two point moorings and lead to chafing and cable failure. Use this mooring type only in controlled and calm applications.

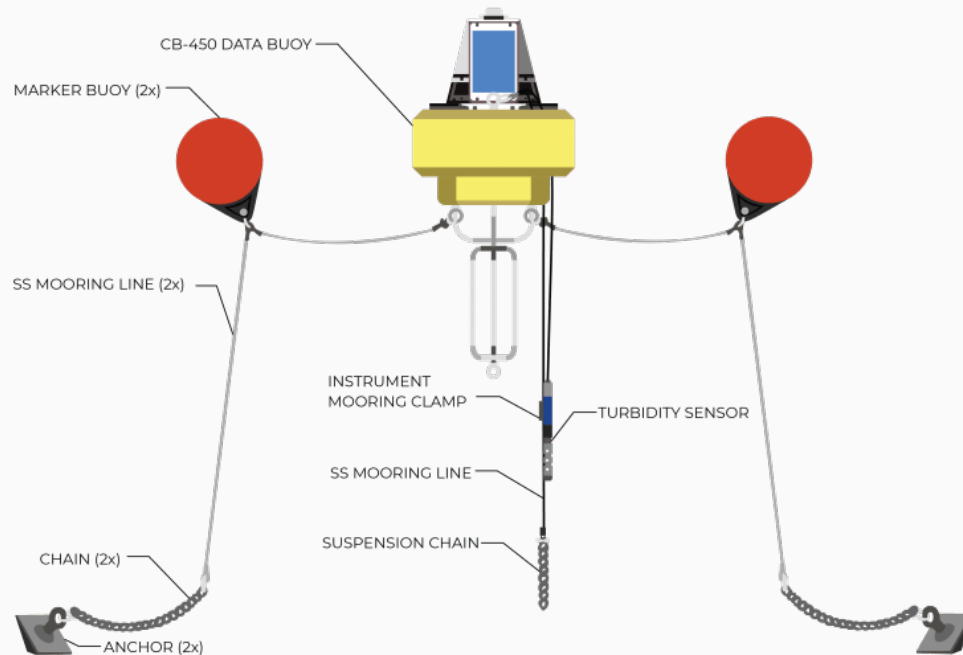
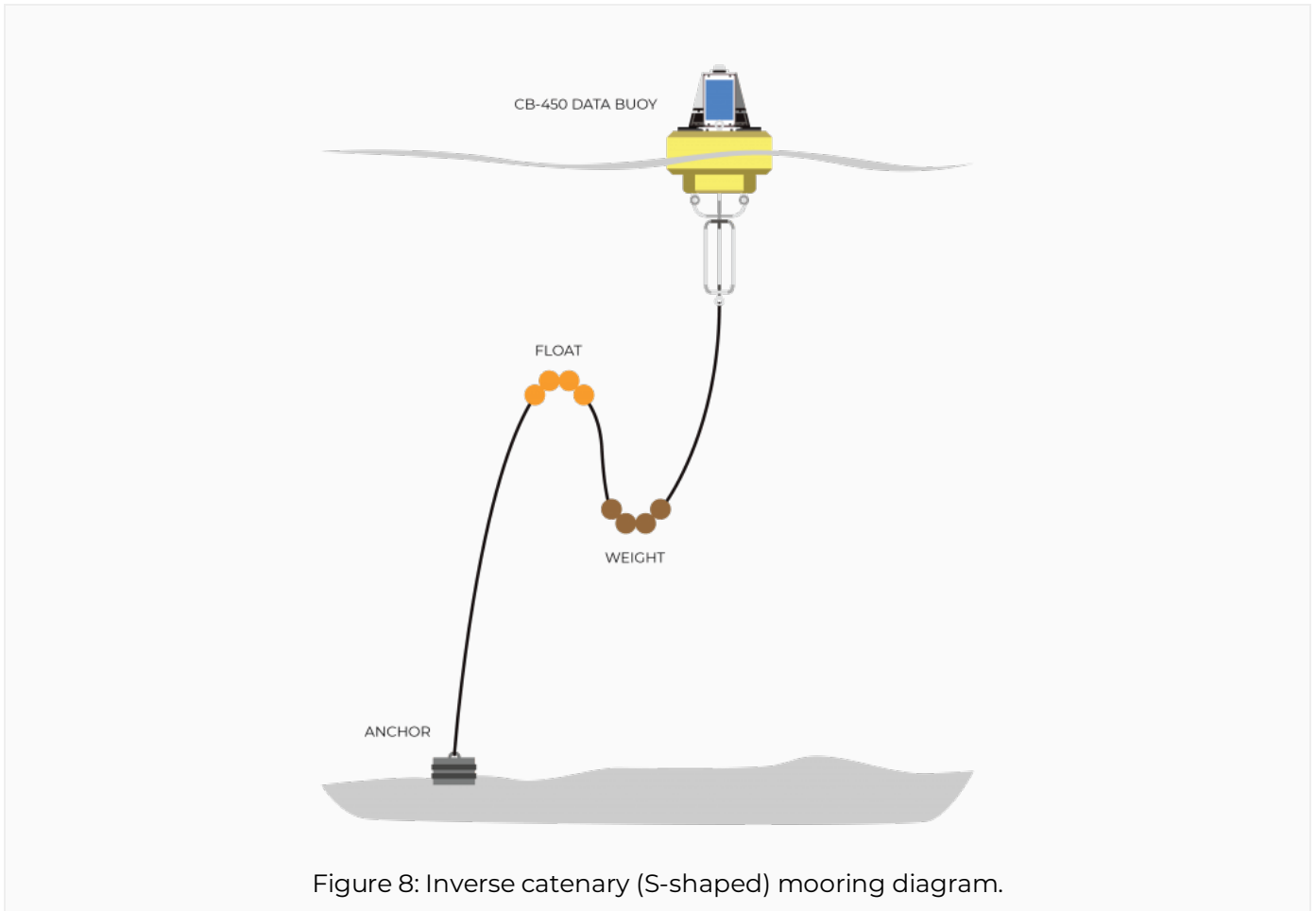

Figure 7: CB-450 data buoy with semi-taut two-point mooring setup.

3. Inverse-catenary (S-shape) moorings

Inverse-catenary moorings are often referred to as S-shaped moorings. Floats and weights on the mooring lines create an S-shape, which provides spring action in the water column. Waves and water level changes are easily managed. This mooring type is most common on deep water deployments but has utility in shallow rough water applications.



CB-Series Data Buoy Deployment Tips

NexSens Technology supplies mooring hardware to support user-designed systems but does not endorse any particular mooring strategy for any specific application and does not take responsibility for mooring performance or damage resulting from mooring failure.

NexSens CB-Series Data Buoys

The NexSens CB-series data buoys contain several mooring eyes on the underside of the buoy hull to accommodate single-point, two-point, and three-point mooring configurations. For two- and three-point moorings, use the mooring eyes located on the bottom of the hull. For single-point, use the mooring eye at the bottom of the buoy frame or instrument cage. Refer to the articles below to learn more about CB-Series buoy characteristics before deployment:

- [Buoy Ballast Weight & Stability](#)
- [NexSens CB-Series Buoy Ballast Weights](#)
- [Mooring Data Buoys](#)

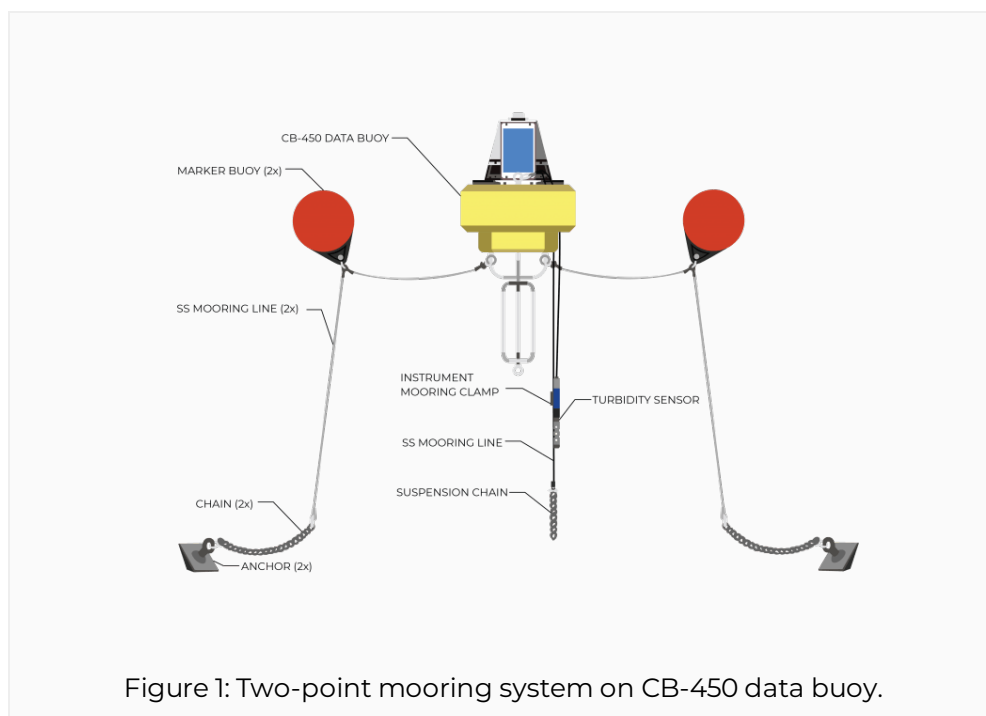

Connecting Mooring Hardware

For NexSens-supplied mooring systems, stainless steel bow shackles connect the various mooring components (i.e., mooring lines, marker buoys, chains, and anchors) together and to the CB-series buoy. 1/2" bow shackles connect mooring lines to the CB-series buoy eyes and 1/2" bottom chains. Larger, 5/8" bow shackles connect to the marker buoys and anchors.

Note: Shackle sizes are dependent on the thickness of the bottom chain. Shackles shown in the images below are used for 1/2" galvanized chain, which is standard in most applications.

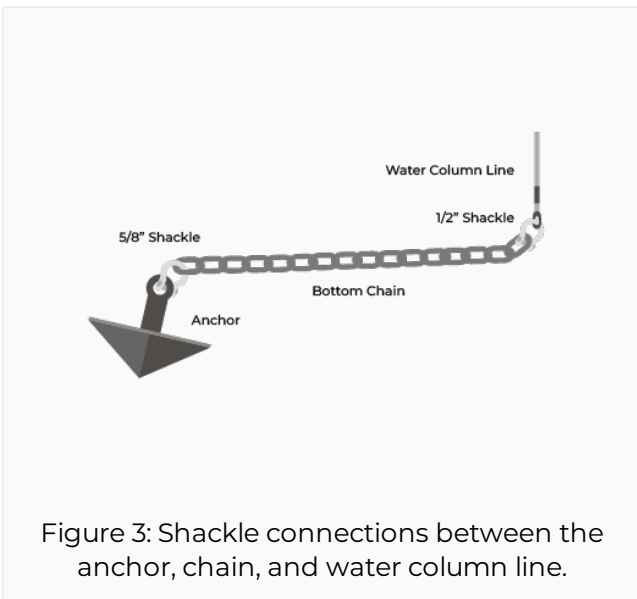
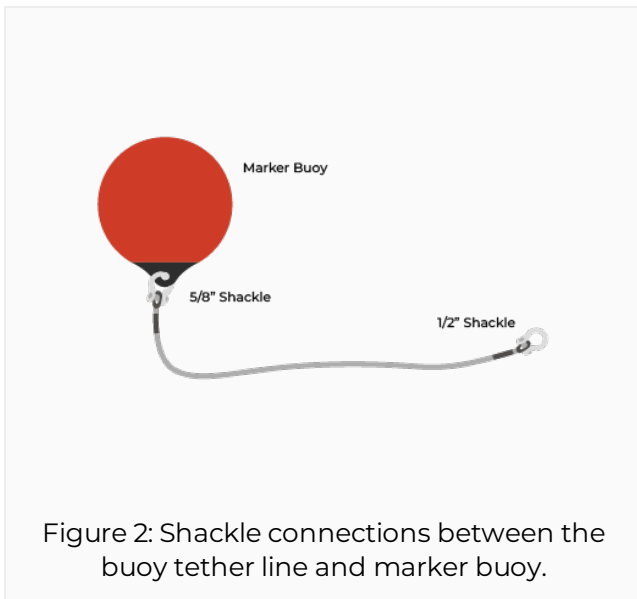

Bow shackles must be properly connected and secured to prevent loosening, especially in rough water conditions. To attach a mooring line, remove the pin from the shackle and run it through the thimble of the mooring line (left image below). Hand-tighten the shackle pin, then use a crescent wrench to tighten the connection. Insert a steel-lined cable tie or stainless steel wire into the hole on the shackle pin and run it through the shackle loop (right image below). Pull tightly to secure, and trim the excess.

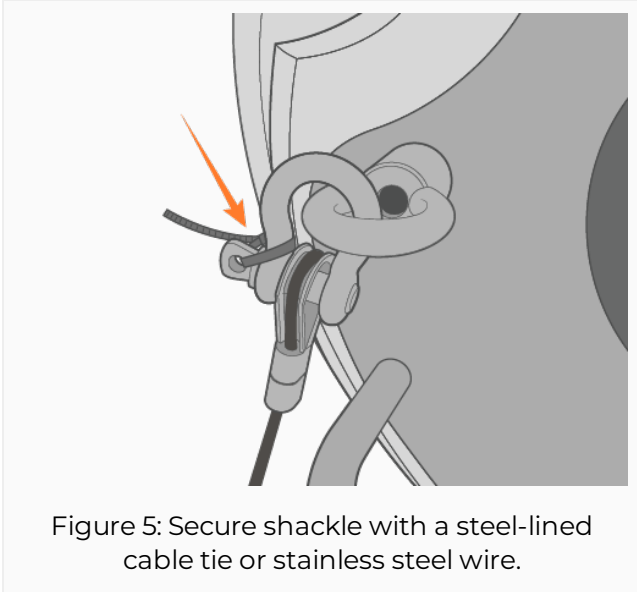
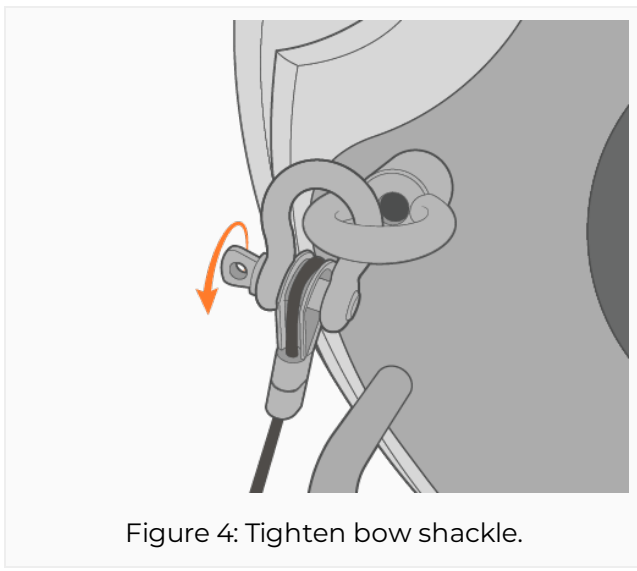

Buoy Deployments

Personnel safety is the number one priority when deploying a data buoy. Using proper equipment (e.g., workboat, lifting rig for heavier systems, gloves, safety footwear, etc.) is essential to deploy any buoy system safely. Buoy systems are heavy, and personnel can quickly become entangled with mooring lines and anchors. Safety and flotation gear should be worn at all times when working on or near the water.

Remember to perform a complete system test onshore before buoy deployments. Learning the system's nuances is better handled onshore or in a lab rather than in the field.



Figure 6: Safe deployment of a buoy system.

Single-Point Mooring Buoy Deployments

1. With the buoy in the boat, begin by connecting all mooring hardware, including the mooring line's connection to the bottom eye of the CB-series buoy.
2. Lift the anchor over the side of the boat and release it in to the water at the chosen deployment location. *Be sure that the mooring line and bottom chain assembly are long enough that dropping the anchor does not pull the buoy over the side of the boat.* Pay out the mooring line so that it does not become entangled.
3. Finalize any sensor connections and apply power, then lift the buoy over the side of the boat and carefully set it in the water.

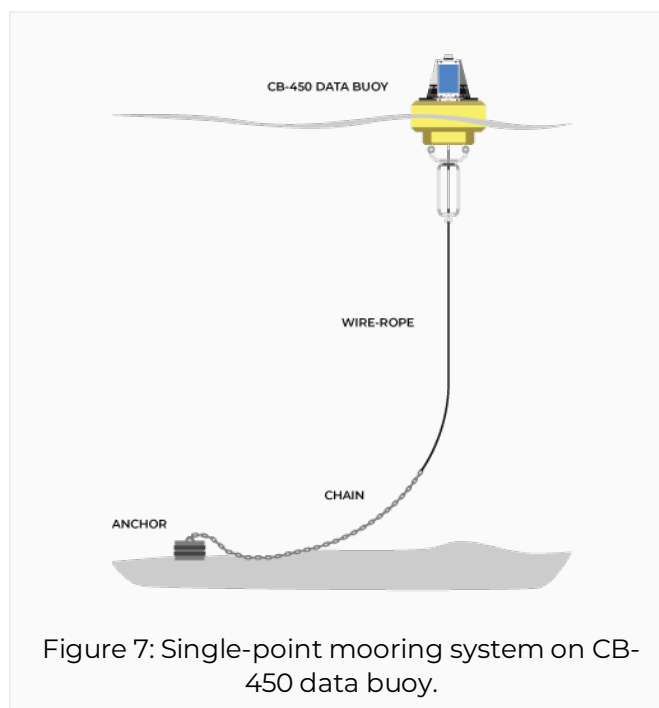

Figure 7: Single-point mooring system on CB-450 data buoy.

Two-Point and Three-Point Mooring Buoy Deployments

1. Connect all mooring components inside the boat. Stage the components so that they can be lifted over the side of the boat and laid out without becoming entangled.
2. Navigate to the chosen location for the first anchor. The distance from the anchor location to the location of the data buoy is best determined by drawing out a diagram of the mooring system and calculating the horizontal distance, taking into account the lengths of the mooring lines and the current water level.
3. Lift the anchor over the side of the boat and place it into the water. Pay out the mooring line as the anchor sinks, using extreme caution to avoid entanglement of the line with personnel and equipment. Place the connected marker buoy in the water.
4. Move to the desired location of the data buoy. Pay out the mooring line from the first marker buoy to the data buoy as the boat is moved.
5. Finalize sensor connections and apply power, then lift the buoy over the side of the boat and set it in the water.
6. Move onward to the location of the second anchor as the mooring line connecting to the second marker buoy is paid out.
7. Drop the marker buoy in the water and continue to the calculated location for the second anchor.
8. Lift the anchor over the side of the boat and lower it into the water.
 - a. Again, pay out the mooring line as the anchor sinks, using extreme caution to avoid entanglement of the mooring line and especially to avoid entanglement of personnel with the mooring line.
9. Repeat this process if a third mooring point is to be used.

Planning a Medium-Deep Water Mooring for Small Data Buoys

Note: NexSens Technology supplies mooring hardware to support user-designed systems but does not endorse any particular mooring strategy for any specific application and does not take responsibility for mooring performance or damage resulting from mooring failure.

Medium-Deep Water Deployment Considerations

While many medium-deep water (>100m depth up to approx. 1000m depth) monitoring projects require large buoy platforms due to sensor loads and corresponding power requirements, there may be some cases where a smaller buoy platform is desirable. This can facilitate measurements from a small package of power-efficient sensors where only near-surface (<50m) measurements are required and provide a solution that is easier to lift and handle by project personnel.

By small data buoys, we are generally referring to CB-Series buoys up to and including the CB-450 model. While these are small and light enough to lift manually by 1-2 persons depending on the model, a medium-deep water mooring system will generally have a sizable anchor weight. As such, a suitable vessel equipped with winch and crane is strongly recommended for lifting and controlled release of equipment to avoid injury to personnel or damage to equipment.

Mooring Configuration

Whereas two-point moorings with suspended sensor lines are often a viable option for shallower applications, medium-deep water moorings will typically be single-point due to the required mooring line length. This means that suspended sensors will be mounted along the primary mooring line, and special care must be taken in the design to ensure that twisting or stretching of data cables does not take place, as this can lead to failure even within a short timeframe.

Some general suggestions and points for consideration when planning this type of deployment are described in the following sections:

Mooring Line Length and Drift Radius

Chains for Controlled Movement vs. Ballast Weight

System Maintenance

Mooring Hardware Materials

Deployment

Mooring Line Length and Drift Radius

In order to determine the appropriate mooring line length, it is first necessary to have a fairly accurate water depth measurement at the deployment site and overview of the expected water level changes. In most applications, mooring line lengths should be ~50% greater than the median water depth to account for water level fluctuations.

The potential drift radius of the buoy, determined by the water depth and mooring line length, is important to calculate to understand if the mooring line will work for the application. The maximum drift radius can be theoretically calculated using Pythagorean theorem as illustrated in the diagram below and using the following formula:

$$r = \sqrt{l^2 - d^2}$$

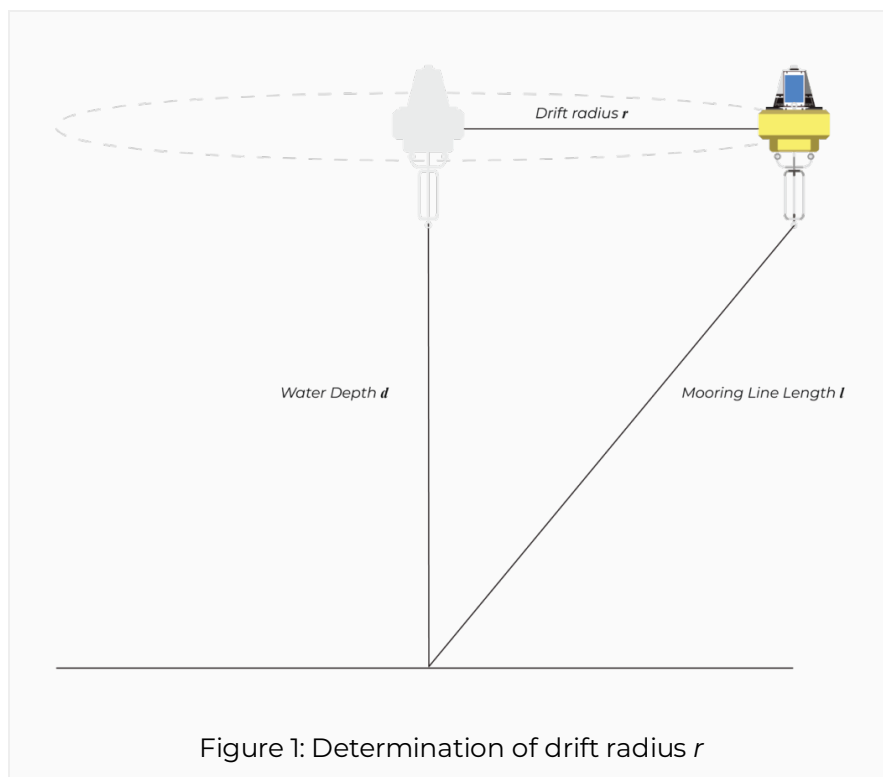

Figure 1: Determination of drift radius r

While this is only a theoretical calculation which may vary in an actual deployment, especially depending on the physical properties of the mooring line, it can serve as a basis for determining the total mooring line length (also see **Mooring Hardware Materials**). Too large of a drift radius may result in the buoy coming into conflict with the shore, infrastructure such as docks, or ship traffic. However, a mooring line that is too short can put the buoy at risk of submersion from horizontal loading during high wave and current conditions. The diagrams below illustrate this effect.

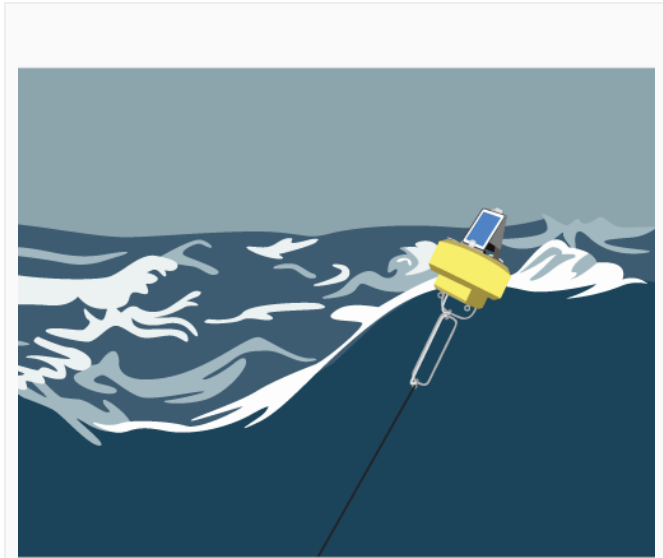

Figure 2: Depiction of horizontal loading resulting in buoy listing to one side.

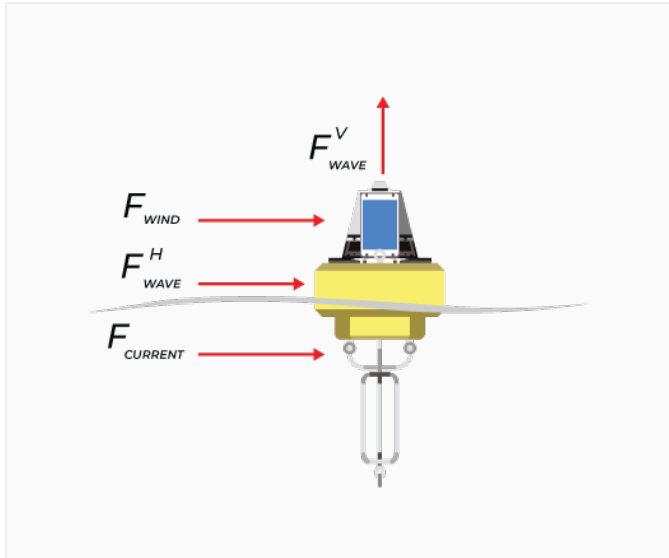
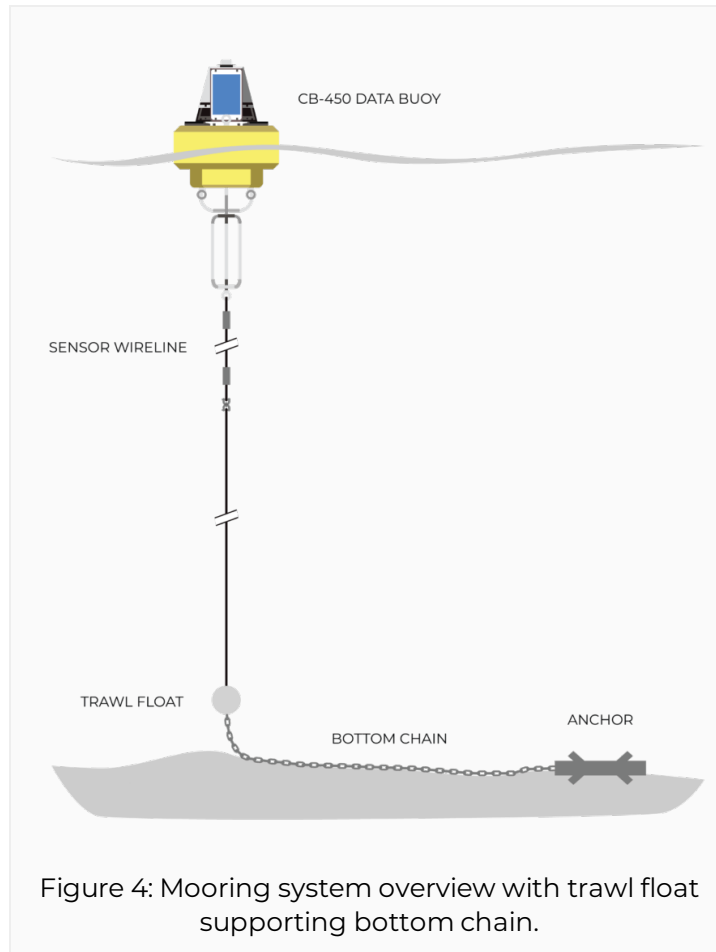

Figure 3: Force diagram representing external forces acting on buoys in natural environments.

Chains for Controlled Movement vs. Ballast Weight

One strategy to provide an adequate potential mooring line length but provide some limitation on the buoy's free movement is to use a heavy bottom chain as a part of the mooring system. The idea of the heavy bottom chain is that it can be lifted up from the seafloor as the buoy is pushed away from its centerline during rough conditions, yet provide enough resistance to dampen this effect.

However, the total buoyancy of the buoy must be carefully considered at this stage, as the chain cannot be too heavy such that it contributes to submersion of the buoy if it becomes fully drawn up from the seafloor. A method for slightly reducing the chain weight while simultaneously preventing it from becoming caught on objects on the seafloor is to install trawl floats at the terminus of the chain, at the location where the primary mooring line is connected. The buoyancy provided by these floats can help to maintain a segment of the chain in suspension as illustrated in Figure 4.



System Maintenance

A secondary consideration in calculation of mooring line length is serviceability of the instruments deployed. For practicality, it may be desirable to be able to access sensors mounted along the mooring line without having to lift the entire anchor system from its placement. This additionally helps to ensure that the buoy remains stationed at precisely the same location both before and after service.

Depending on sensor depths, this may or may not be achievable, but it will be theoretically possible any time the sensor depth is less than the drift radius, provided that maintenance is carried out under low and/or calm water conditions. Heavy chain connected to the anchor can also contribute to facilitating this, since it normally rests on the seafloor and contributes to anchor weight but may be lifted up during maintenance (preferably with the assistance of a winch or crane on the service vessel).

The diagram in the previous section illustrates an example where placement of the two sensors is less than the drift radius when accounting for the bottom chain length, so it should be possible to access the sensors for maintenance without disturbing the anchor placement.

Mooring Hardware Materials

Mooring Lines

A wide range of hardware options are available, and these can largely be selected based on site conditions, but there are a few critical points which should be considered.

Sensors suspended below the buoy frame can optionally be mounted onto NexSens-issued [stainless steel mooring lines](#). Sensors can be securely mounted using [MC-600 mooring clamps](#) specifically designed for use with these mooring lines.

Buoyancy Control

Due to the weight of such wirelines, it is often preferable to use a neutral-buoyancy or even net positive buoyancy mooring rope with sufficient strength to perform well in the site conditions, for example Superdan[®] 8-strand or 12-strand ropes. Mooring lines with elastic properties may also help to reduce the total line length required and thereby reduce the drift radius as well.

If a positive buoyancy rope is used, this may result in some slack in the mooring line especially during calm conditions, thus forming a so-called S-shaped mooring as pictured in the diagram below. A potential issue with this is rope floating up and coming into contact with sensors, which can cause measurement interference, particularly on optical sensors. Rope floating all the way to near the surface can also present a risk of being snagged by passing boat/ship traffic. For those reasons, some weight should be added to limit the amount of flotation that can occur, similar to what is illustrated in the figure. However, it is important to keep in mind that this will count against the net buoyancy provided by the buoy.

Biofouling resulting in growth on mooring lines can also contribute additional weight during a deployment, so buoys and mooring lines should be periodically inspected and cleaned to ensure there are no issues. Any visual change to the way the buoy sits on the water surface during calm conditions (e.g. listing or sitting lower than normal) should immediately be inspected.

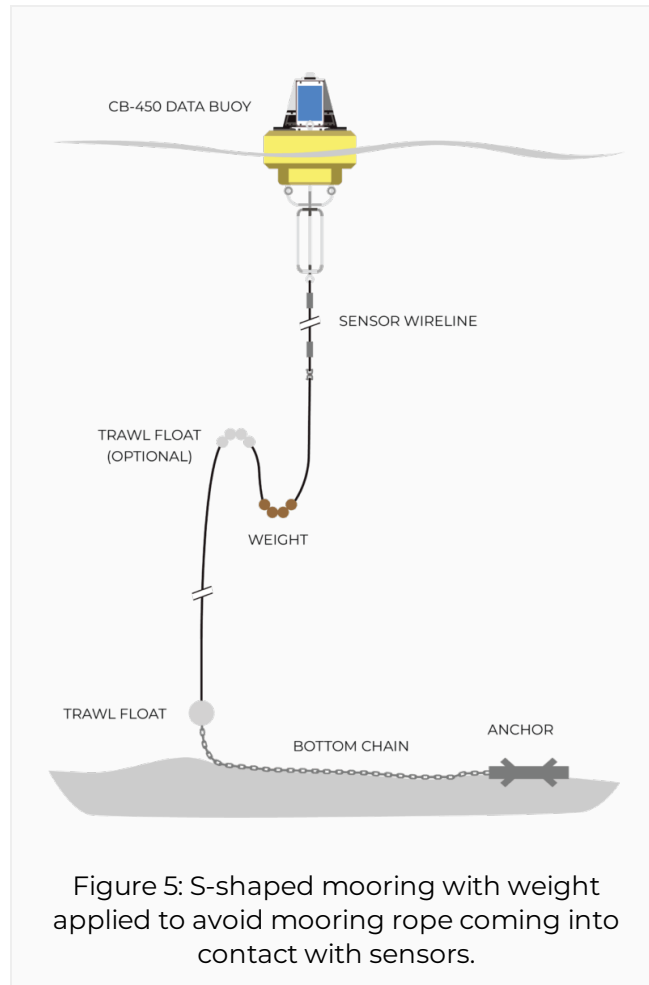

Mooring Connections

To connect mooring components together, various shackle types may be used. Here, it is important to consider the materials of construction. The internal frame of CB-Series buoys is constructed of Type 316 stainless steel. Thus, to avoid mixing metals, any shackles connected directly to the buoy should also be made of 316 stainless steel.

At the seafloor, galvanized steel shackles, bottom chain and anchors may be used, provided there is consistency of materials. To guard against corrosion in saltwater environments, the buoy frame should be equipped with zinc anodes (NexSens part number [CB-ZA](#)).

Sensor Cable Protection

For protection of sensor data cables, it is recommended to secure the cable using steel-lined cable ties at many points along the sensor wireline (or equivalent mooring line). This is to ensure that there is plenty of slack in the data cable and that all loads are carried by the wireline/mooring line and NOT the data cable. Twisting in the wireline should be reduced as much as possible. This can, in some cases, be achieved by using a stainless steel swivel at the point where the wireline connects to the primary buoy mooring line. A swivel should NOT be used directly at the connection to the buoy frame, as this will allow the buoy to rotate around the mooring line connection. An exception to this would be if no sensors are suspended below the depth of the buoy's internal frame.

Deployment

Due to the size and total weight of medium-deep water moorings, it is strongly recommended to deploy using an appropriately-sized vessel equipped with a crane and winch for controlled lifting and release of the mooring system and buoy. The following describes the process for a typical deployment.

1. Lay out the buoy and mooring hardware on the vessel's deck such that all connections can be made and the mooring line can be paid out without risk of tangling.



Figure 6: Buoy mooring hardware carefully arranged on deck to avoid tangling.

2. Use the crane to lift the heavy anchor and carefully lower it over the side of the vessel at the deployment site. Use the winch to hold the mooring rope such that the release is controlled throughout.
 - a. Tip: To pay out the anchor and bottom chain without having to run the chain through the winch, an off-load hook (e.g. from Henriksen or equivalent) is a handy helping device. Commonly used with lifeboats, these hooks have an automatic self-open function that causes the hook to release when the load is released. Using the winch to support the rope connected to the chain, lower the anchor into the water deep enough that the anchor load begins to be carried by the chain connected to the winch-supported rope rather than the crane, and the anchor will be released in a very controlled manner.



Figure 7:
Anchor
supported by
off-load hook.

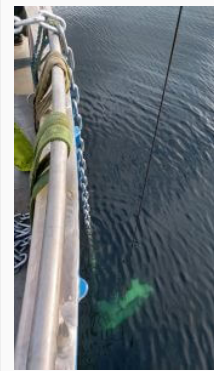

Figure 8:
Anchor being
lowered into
water with
crane.

3. After drawing the wire of the crane back to its original parked position, begin slowly paying out the mooring line using the winch. Before the anchor touches the seafloor, there is the possibility to make fine adjustments to the mooring location by carefully navigating the vessel, being sure to avoid tangling of the mooring line with the motor.



Figure 9: Paying out the mooring line using the winch.

4. Once the entirety of the mooring line is paid out, be sure to double check all sensor

connections and that the buoy and LED beacon are powered up. Then, carefully place the buoy in the water. This can either be done by lifting it and placing it with the crane and off-load hook as with the anchor, or by placing it into the water through a bow gate if the vessel is equipped with one.

Once deployed, observe the buoy's movement to ensure it appears to be stable. If the buoy is equipped with a GPS device, track the coordinates for a few days to ensure it is staying within the desired drift radius, and consider configuring a geofence alarm to provide notice if the buoy moves outside the desired boundaries.

4. Warranty

NexSens Technology, Inc. warrants products against defects in materials or workmanship for a period of 12 months from the date of delivery to the original customer. This warranty is limited to the replacement or repair of such defects, without charge, when the product is returned to NexSens Technology, Inc. Damage due to accidents, misuse, tampering, lack of reasonable care, loss of parts, failure to perform prescribed maintenance, or accidents of nature are not covered. This warranty excludes all other warranties, express or implied, and is limited to a value not exceeding the purchase price of the instrument.

Limitation of Warranty

This warranty is not applicable to any NexSens Technology, Inc. product damage or failure caused by failure to install, operate or use the product in accordance with NexSens Technology, Inc. written instructions; abuse or misuse of the product; failure to maintain the product in accordance with NexSens Technology, Inc. written instructions; any improper customer repairs to the product; use by the customer of defective or improper components or parts in servicing or repairing the product; or customer modification of the product in any way not expressly authorized by NexSens Technology, Inc.

NexSens Technology, Inc. products are not authorized for use as critical components in any life support system where failure of the product may affect its safety or effectiveness.

Corporate Headquarters & Authorized Service Center

NexSens Technology, Inc.
2091 Exchange Court
Fairborn, OH 45324
Phone: 937.426.2703 | Fax: 937.426.1125
Email: support@nexsens.com

5. Service Request

Service Request

To return equipment for evaluation and repair, request Return Authorization (RA) at the following link:

[NexSens Return Authorization](#)

An email authorization receipt with a reference number will be sent to print and include with your shipment.

Products within the warranty period will be fixed at no charge. Initial evaluations are performed at no cost, and a quote will be provided if charges apply.

For additional support or inquiries, email support@nexsens.com.