



1415 Research Park Drive • Beaver Creek • OH • 45432  
Phone: (937) 426-2703 • Fax: (937) 426-1125 • E-Mail: [info@NexSens.com](mailto:info@NexSens.com)  
Visit us on the web at <http://www.NexSens.com>

**weatherVIC Software**  
**Operations Manual and Reference Guide**  
**Revision 05.07.06**



## TABLE OF CONTENTS

<b>1</b>	<b><i>Introduction</i></b> .....	<b>6</b>
1.1	About NexSens Technology, Inc. ....	6
1.2	How to Use This Manual .....	6
1.3	System Requirements.....	7
1.4	Software Installation .....	7
1.5	Important Notice .....	7
1.6	Uninstalling weatherVIC .....	7
<b>2</b>	<b><i>Technical Information</i></b> .....	<b>8</b>
2.1	Vaisala WXT510 Specifications.....	8
2.2	Internal WXT510 Wiring.....	10
<b>3</b>	<b><i>Vaisala WXT510 Installation</i></b> .....	<b>11</b>
3.1	Selecting A Location.....	11
3.2	Assembling The WXT510 .....	11
3.3	Mounting.....	12
3.4	Wind Direction Correction .....	13
<b>4</b>	<b><i>weatherVIC Software</i></b> .....	<b>14</b>
4.1	About weatherVIC Software.....	14
4.2	Running weatherVIC For The First Time.....	15
4.3	Getting Help and Software Updates .....	16
4.4	Changing Sensor Configuration.....	17
4.5	Virtual Instrument Control View .....	18
4.6	Graphical Panel View .....	19
4.7	Generate a Historical Data Report .....	20
<b>5</b>	<b><i>Working With Data</i></b> .....	<b>21</b>
5.1	Report Tools.....	21
5.2	Report Menu .....	21
5.3	Page Property .....	22
5.4	General Tab.....	24
5.5	Advanced Tab .....	26
5.6	Graph Property Tab.....	27
	<b><i>Appendix A: weatherVIC Quick Tutorial</i></b> .....	<b>28</b>
	<b><i>Appendix B: Troubleshooting weatherVIC Display</i></b> .....	<b>36</b>

## END USER LICENSE AGREEMENT ("EULA")

NOTICE: Please CAREFULLY read this EULA. If you install or use this software product(s) (the "SOFTWARE"), you will be legally bound by this EULA. If you do not want to be bound by this EULA, you must promptly return the SOFTWARE and all accompanying documentations in the original packaging to the place where you obtained them for a full refund. If you do not accept this EULA, you may not copy, retain or use the SOFTWARE.

1. LICENSE GRANT. (a) NexSens Technology, Incorporated ("NEXSENS"), grants you a non-exclusive license to use the SOFTWARE, subject to the following:

Except as stated below, you may install the SOFTWARE on only one computer. If the SOFTWARE can be used from any computer other than the computer on which it is installed (whether because the computer on which it is installed is part of a network or for any other reason), you must license a copy of the SOFTWARE for each computer from which the SOFTWARE may be used.

If you are the primary user of more than one computer, you may install the SOFTWARE on each of them so long as the SOFTWARE is never used on more than one of the computers at the same time. If you want to allow the SOFTWARE to be used on more than one of the computers at the same time, then you must license a copy of the SOFTWARE for each computer.

You may make a reasonable number of back-up copies of the SOFTWARE. The back-up copies may be used only to replace an unusable copy of the SOFTWARE. You must destroy any copies of the SOFTWARE that are replaced by a back-up copy. Back-up copies must include all proprietary rights and notices appearing on the original and must remain in your possession or control.

You may, after written notification to NEXSENS, transfer the SOFTWARE on a permanent basis to another person or entity, provided you retain no copies of the SOFTWARE and the recipient agrees to the terms of this EULA. If you have received an update to the SOFTWARE, any transfer must include the update and all prior versions of the SOFTWARE.

Except as specifically permitted in this EULA, you may not (i) copy the SOFTWARE, (ii) modify the SOFTWARE or extract any of its components for use with other software (iii) decompile, disassemble, reverse engineer, or make any attempt to discover the source code of the SOFTWARE (iv) sublicense, rent, or lease any portion of the SOFTWARE.

You may not allow anyone to do anything that this EULA prohibits you from doing.

(b) You understand that the SOFTWARE is licensed to you and not sold. NEXSENS retains title to all copies of the SOFTWARE.

2. LIMITED WARRANTIES AND DISCLAIMER OF IMPLIED WARRANTIES. (a) NEXSENS warrants that, for thirty (30) days after you obtain the SOFTWARE (the "Warranty Period"), (i) the SOFTWARE will perform substantially in accordance with the enclosed user documentation, and (ii) the disks or other media on which the SOFTWARE is distributed will be free of defects in material and workmanship. This limited warranty does not cover anything caused by accident or abuse or by use of the SOFTWARE other than for its reasonably intended purposes and as recommended in the accompanying user documentation. Also, NEXSENS does not warrant that the operation of the SOFTWARE will be uninterrupted or error free. Furthermore, any written or oral information or advice given by NEXSENS distributors, agents, or employees will in no way increase the scope of this limited warranty. This warranty gives you specific legal rights, and you may also have other rights, which vary from state to state.

(b) Except as stated in Section 2(a), NEXSENS does not make any warranties. In particular, NEXSENS disclaims all implied warranties, including the implied warranties of merchantability, fitness for a particular purpose, and non-infringement. The duration of any implied warranty that is not effectively disclaimed will be limited to the 30 day Warranty Period. Some states do not apply limitations on how long an implied warranty lasts, so the above limitation may not apply to you.

3. EXCLUSIVE REMEDIES. (a) If, during the Warranty Period, you report any breach of warranty to NEXSENS and NEXSENS is reasonably able to verify that breach, NEXSENS or its agent will, at its option, either (i) correct the SOFTWARE or replace any defective media, (ii) help you work around or avoid the problem, or (iii) allow you to return the SOFTWARE and all accompanying documentation in the original packaging for a full refund. If you return the SOFTWARE for a refund, you may not retain or use the SOFTWARE, and you must immediately destroy all back-up copies and any other copies of the SOFTWARE in your possession or control.

(b) During the Warranty Period, you may report breaches of warranty by contacting NEXSENS Customer Service. You must describe the breach in detail and include a phone number or address at which you can be reached during normal business hours. NEXSENS will respond within a reasonable time to any reported breach. You must pay all costs of shipping any SOFTWARE or other materials. Any corrected or replaced software that you obtain under this EULA will be considered part of the SOFTWARE licensed under this EULA and will be covered by warranty only for any time remaining in the original Warranty Period.

(c) The remedies stated in this Section 3 are your only rights or remedies, and will be NEXSENS's only liability or obligation, for any breach by NEXSENS of any warranty.

4. PROPRIETARY RIGHTS. Subject to this EULA, NEXSENS and its licensors retain all copyrights, trade secret rights, patents, trademarks, and any other proprietary rights covering or relating to the SOFTWARE. You acknowledge that the SOFTWARE includes or incorporates proprietary and confidential information belonging to NEXSENS and/or its licensors. All rights not expressly granted by NEXSENS in this EULA are reserved.

5. EXCLUSION OF CONSEQUENTIAL DAMAGES; LIMITATION OF LIABILITY. Neither NEXSENS nor its affiliates nor its licensors will be liable for any special, incidental, consequential or exemplary damages, including without limitation damages for loss of use, lost profits or loss of data or information of any kind, arising out of or in connection with the SOFTWARE or its use or this EULA, even if NEXSENS or its affiliates or its licensor have been advised of the possibility of such damages. In no event will NEXSENS's or its affiliates' or its licensors' liability for any claim relating to the SOFTWARE or its use or this EULA, whether in contract, tort or any other theory of liability, exceed the license fee paid by you. Some states do not allow the exclusion or limitation of incidental or consequential damages, so the above limitation or exclusion may not apply to you.

6. CAUTIONS REGARDING DATA. The SOFTWARE contains tools to be used in transmitting, searching, and retrieving data in various forms as described in the documentation. You assume the entire responsibility for determining the legality of any transmission or copying you may engage in and for protecting yourself, your business, and associates from any offensive or inaccurate data, information, or material you may choose to receive or allow to be transmitted to you. NEXSENS does not grant any warranty with respect to, or assume any responsibility for any consequences whatsoever suffered by any person as a result of, your access or use of the Internet including, without limitation, access to or resulting in false, incomplete or unreliable data, computer viruses, or corrupted data.

7. EXPORT. You acknowledge that the SOFTWARE is subject to United States export control laws, including the export administration regulations. You will not export, re-export or divert the SOFTWARE in contravention of those laws.

8. TERMINATION. NEXSENS may terminate this EULA if you violate it. You must destroy all copies of the SOFTWARE in your possession or control promptly upon termination. Upon NEXSENS's request, you must certify in writing that you have complied with your obligations under this Section 8 and otherwise under this EULA. Termination by NEXSENS will not limit any of its other rights or remedies under this EULA or at law or in equity. Any provision of this EULA that by its sense and context is intended to survive termination of this EULA will survive termination.

9. SEVERABILITY. If any provision of this EULA is illegal or unenforceable under applicable law, the remaining provisions of this EULA will remain valid and fully enforceable. If any provision is in part enforceable and in part unenforceable, it will be enforced to the extent permitted under applicable law.

10. U.S. GOVERNMENT RESTRICTED RIGHTS. The SOFTWARE and documentation are provided with RESTRICTED RIGHTS. If this product is licensed by any agency or instrumentality of the United States of America, use, duplication and disclosure are subject to restriction as set forth in subparagraphs (a) - (d) of the rights in Technical Data and Computer Software clause at FAR 52.227-19 or any successor regulation, or in subdivisions (c)(1) and (2) of the Commercial Computer Software Restricted Rights clause at 48 FAR 52.227-7013 or any successor regulation, or as set forth in the particular department or agency regulations or rules which provide NEXSENS or its licensors protection equivalent to or greater than that clause. The contractor/manufacture is NexSens Technology, Incorporated, 1415 Research Park Drive Dayton, Ohio 45432.

11. ENTIRE AGREEMENT. This EULA, together with any special rights or promotions provided in writing with your copy of the SOFTWARE, is the entire agreement between you and NEXSENS relating to the SOFTWARE. It supersedes any prior or contemporaneous oral or written communication relating to the SOFTWARE.

If you have any questions concerning this EULA, please contact in writing: NexSens Technology, Incorporated, 1415 Research Park Drive Dayton, Ohio 45432



# 1 Introduction

## 1.1 About NexSens Technology, Inc.

NexSens Technology, Inc. was started in the 1990s with a mission to advance the capabilities and simplify the development of environmental monitoring systems. Our main focus is on the creation of easy-to-use computer software and powerful communications equipment to provide advanced remote data acquisition and datalogging services.

weatherVIC is an easy-to-learn, easy-to-use Windows based software program designed to work with the Vaisala WXT510 multi-weather parameter system. weatherVIC automates all of the tedious programming, data collection and manual data processing common with other environmental data collection systems. It also includes a powerful and graphically pleasing user interface. weatherVIC provides a real-time connection to weather data as well as advanced reporting features for your studies.

The NexSens iSIC (Intelligent Sensor Interface and Control) is a state-of-the-art datalogger that simplifies the collection of real-time data from environmental sensors and monitoring instruments. It includes support for multi-vendor sensor connections and is fully compatible with NexSens communication equipment and software.

## 1.2 How to Use This Manual

This manual is designed to provide you with instructions for getting started and contains detailed reference information on the operation of NexSens weatherVIC software. As with any new software package, it is a good idea to read the documentation thoroughly before attempting to setup and operate the program.

This manual should provide you with the information needed to use the weatherVIC software. If you experience difficulty, we suggest you follow the procedure below:

- Review the subject in the manual.
- Check for software updates. In the main screen of weatherVIC click on the side slide out bar. Then click on the **Check for Updates** button. weatherVIC will automatically check the internet for a newer version and update the software if it is not the latest.
- Review the Frequently Asked Questions (F.A.Q.) on the NexSens web page:  
<http://www.nexsens.com/support/faq.htm>

If you are still having difficulty, email your technical support question to: [info@NexSens.com](mailto:info@NexSens.com)

### 1.3 System Requirements

weatherVIC requires the following minimum system configuration:

- Pentium class PC
- 64 MB RAM
- 100 MB hard drive
- 2MB video card
- CD-ROM drive for software installation
- Windows 2000 (SP1 or higher), XP, 2003
- Macromedia Flash
- Adobe Acrobat Reader (to view pdf manual)

For better performance and reliability, twice the minimum system configuration is recommended.

ActiveX controls must be enabled in internet explorer in order for Panel View to be displayed.

### 1.4 Software Installation

weatherVIC is distributed on CD-ROM. The setup program starts automatically when the CD is inserted. If not, you can manually start the setup process by following the steps below. We suggest that you accept the default options presented by the weatherVIC setup program.

Double click **My Computer**.

Double click the CD-ROM drive to open weatherVIC CD.

Double click **Setup.exe** or **Setup** icon to start the installation program.

During the installation, you will be asked to register weatherVIC software. You can either print the registration form and mail or fax it to NexSens or connect to the Internet and register online. By registering within 30 days of purchasing weatherVIC, you are eligible for 2 years of free software updates.

After installation is complete, you can run weatherVIC from the start menu **Program | NexSens | weatherVIC**. For your convenience a shortcut to weatherVIC is also placed on your desktop.

### 1.5 Important Notice

Managing your environmental data and information is a formidable task. weatherVIC simplifies this effort and organizes your important data. Be sure to backup your database and other important files on a regular basis.

### 1.6 Uninstalling weatherVIC

To uninstall weatherVIC, click **Settings** in the **Start Menu**. Select **Control Panel** and then **Add / Remove Programs**. Follow the instructions to remove weatherVIC and all associated files.

## 2 Technical Information

### 2.1 Vaisala WXT510 Specifications

#### Wind speed

Range	0...60 m/s
Accuracy	±0.3 m/s or ±3%, whichever is greater ±3% for 0-35 m/s ±5% for 36-60 m/s
Resolution	0.1 m/s (km/h, mph, knots)

#### Wind direction

Range	0...360°
Accuracy	±3°
Resolution	1°

#### Liquid precipitation

Rainfall	cumulative accumulation after latest automatic or manual reset
Accuracy	5%
Rain duration	counting each ten second increment when droplet detected
Rain intensity	one minute running average in ten second steps
Resolution	0.01 mm (0.001 in)

#### Barometric pressure

Range	600...1100 hPa
Accuracy	±0.5 hPa at 0...30 °C (+32...+86 °F) ±1 hPa at -52...+60 °C (-60...+140 °F)
Resolution	0.1 hPa, 10 Pa, 0.0001 bar, 0.1 mmHg, 0.01 inHg

#### Air temperature

Range	-52...+60 °C (-60...+140 °F)
Accuracy at +20°C (+68°F)	±0.3 °C (±0.5 °F)
Resolution	0.1 °C (0.1°F)

#### Relative humidity

Range	0...100 %RH
Accuracy	±3 %RH within 0...90 %RH ±5 %RH within 90...100 %RH
Resolution	0.1 %RH

Communication Settings: 19200 baud, No Parity, 8 Data Bits, 1 Stop Bit, ASCII polled (without CRC)

These are the default WXT510 communication settings. See the WXT510 manual for additional information. Under normal circumstances these settings will not have to be changed.

Here are the settings we used for the WXT510:

- Communication protocol: ASCII, polled (M=P)
- Serial Interface: RS-232 (C=2)
- Baud rate: 19200 (B=19200)
- Data bits: 8 (D=8)
- Parity: None (P=N)
- Stop Bits: 1 (S=1)

## 2.2 Internal WXT510 Wiring

Below is the internal sensor wiring of the WXT510. The weatherVIC WXT510 comes pre-wired and will not have to be assembled. This diagram is shown for documentation purposes only and under normal circumstances will not have to be used.

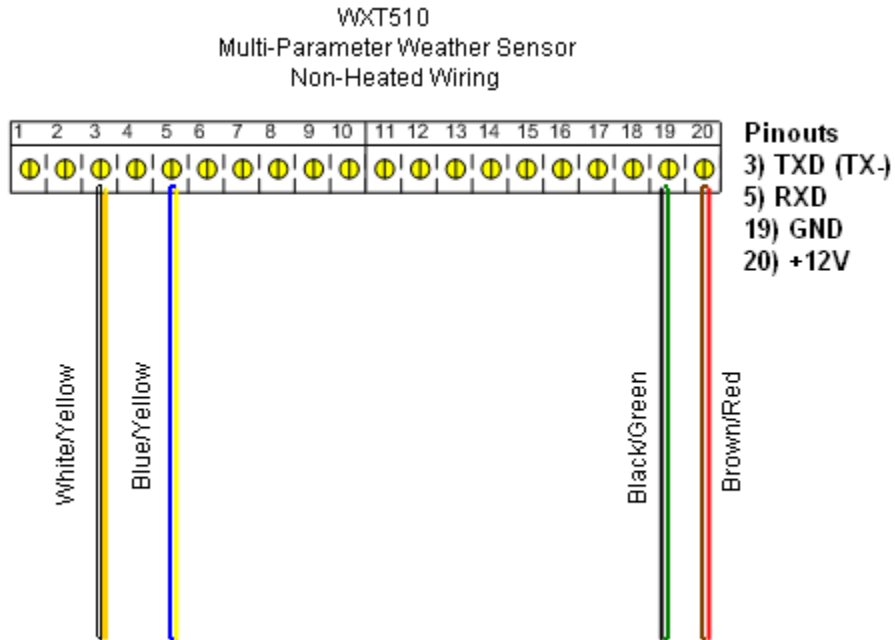

When wired for the heated version, pin 20 is jumpered to pin 18 and pin 19 is jumpered to pin 17.

**IMPORTANT: The WXT510 requires constant power to operate. Always have the power supply adapter plugged and constantly on. A surge protector is recommended to prevent damaging the WXT510.**

Wiring Table:

<u>Wire 1</u>	<u>Wire 2</u>	<u>WXT510 Pin</u>	<u>DB9 Pin and Signal</u>
Green	Black	WXT510 Pin 19 (and 17 in heated version)	Ground PC Pin 5
Red	Brown	WXT510 Pin 20 (and 18 in heated version)	Power +12V
White	Orange	WXT510 Pin 3	Rx PC Pin 2
Blue	Yellow	WXT510 Pin 5	Tx PC Pin 3

\*Note: If you are using your own cable, the colors may vary. It is highly recommended to use shielded twisted pair cable. For distances greater than 100ft a separate cable should be used for power.

## 3 Vaisala WXT510 Installation

### 3.1 Selecting A Location

Finding a suitable site for the WXT510 is important for getting correct readings. The site should represent the general area of interest. The Vaisala WXT510 should be installed in a location that is free from wind interference caused by nearby objects, such as trees or buildings.

### 3.2 Assembling The WXT510

Before the WXT510 can be used, the protective cap covering the Relative Humidity sensor should be removed and the PTU module installed. This can be accomplished in three easy steps:

1. Use a flat head screw driver to loosen the three fixing screws.
2. Gently pull the top of the WXT510 off of the body and remove the protective cap.
3. Replace the top and tighten the three fixing screws that fasten the top to the bottom.

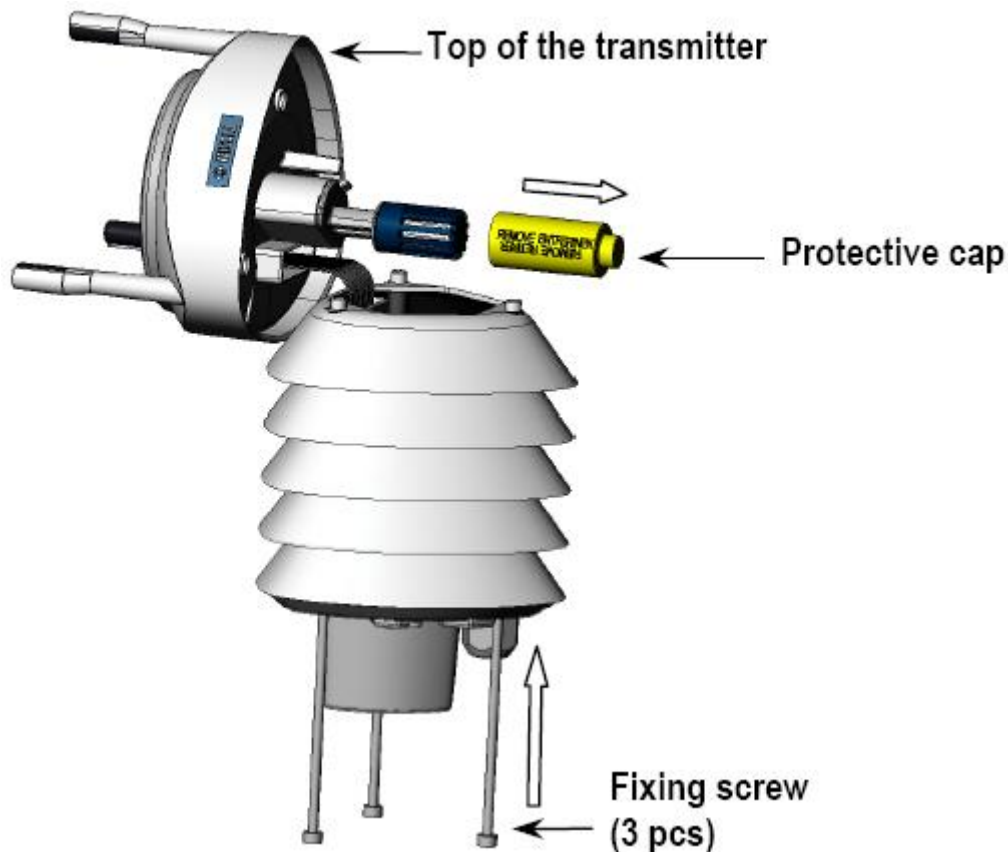

At the measurement site, the WXT510 will then need to be mounted and aligned.

### 3.3 Mounting

The WXT510 must be installed in an upright, vertical position.

To mount the WXT510 onto a vertical pole mast, simply remove the screw cover and insert the WXT510 onto the pole mast. Align it in such a way that the arrow points to north; see the next section for details. Then tighten the fixing screw and replace the screw cover.

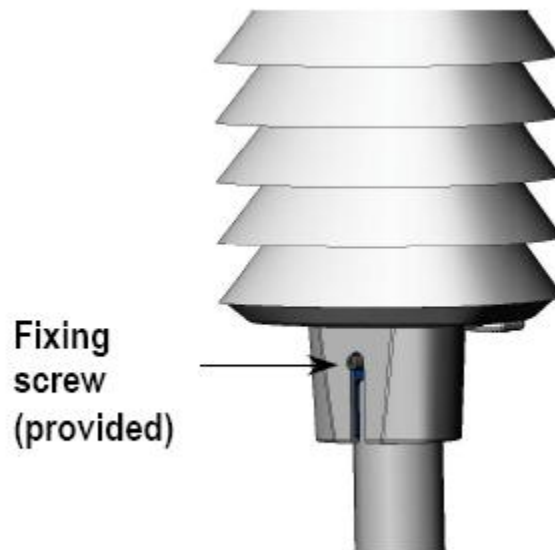

To mount the WXT510 onto a horizontal cross arm, simply remove the screw cover, and place the WXT510 into the cross arm by using the fixing screw (M6 DIN933) and a nut; as shown in the picture below. Align it in such a way that the arrow points to north; see the next section for details. Then tighten the fixing screw and replace the screw cover.

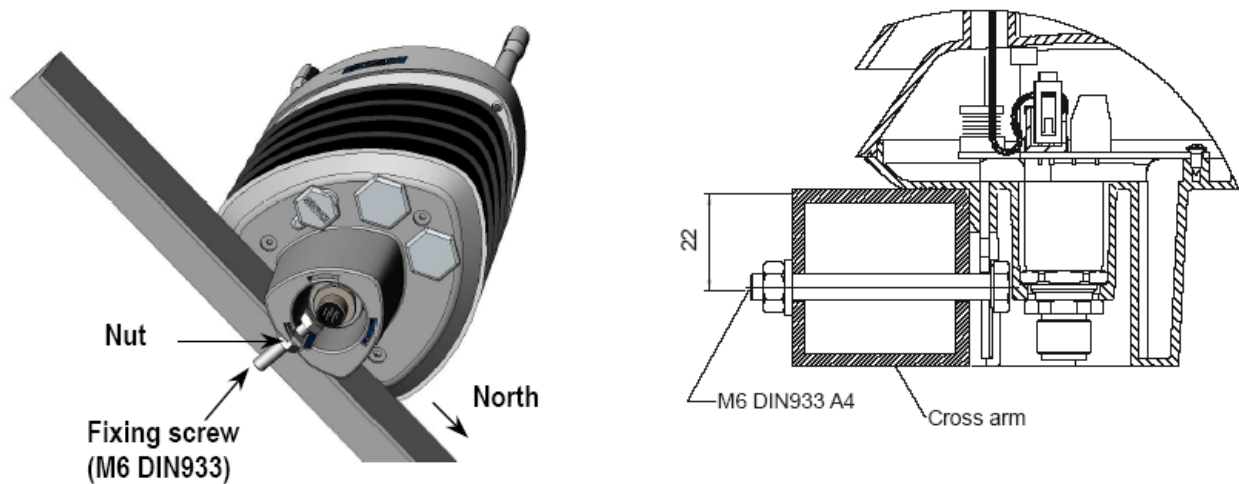

To help the alignment, there is an arrow and the text **North** on the bottom of the WXT510. It should be aligned in such a way that this arrow points to the north. Wind direction can be referred either the true north, which uses the earth's geographic meridians, or to the magnetic north, which is read with a magnetic compass. The magnetic declination is the difference in degrees between the true north and magnetic north.

To align Weather Transmitter WXT510, proceed as follows:

1. If the WXT510 is already mounted, loosen the fixing screw on the bottom of the transmitter so that you can rotate the device.
2. Use a compass to determine that the transducer heads of WXT510 are exactly in line with the compass and that the arrow on the bottom of WXT510 points to the north.
3. Tighten the fixing screw on the bottom of the transmitter when the bottom arrow is exactly aligned to north.

### 3.4 Wind Direction Correction

In case the WXT510 cannot be aligned in such a way that the arrow on the bottom points to the north, a wind direction correction will have to be made. Record the deviation angle, as this will be used by the software later.

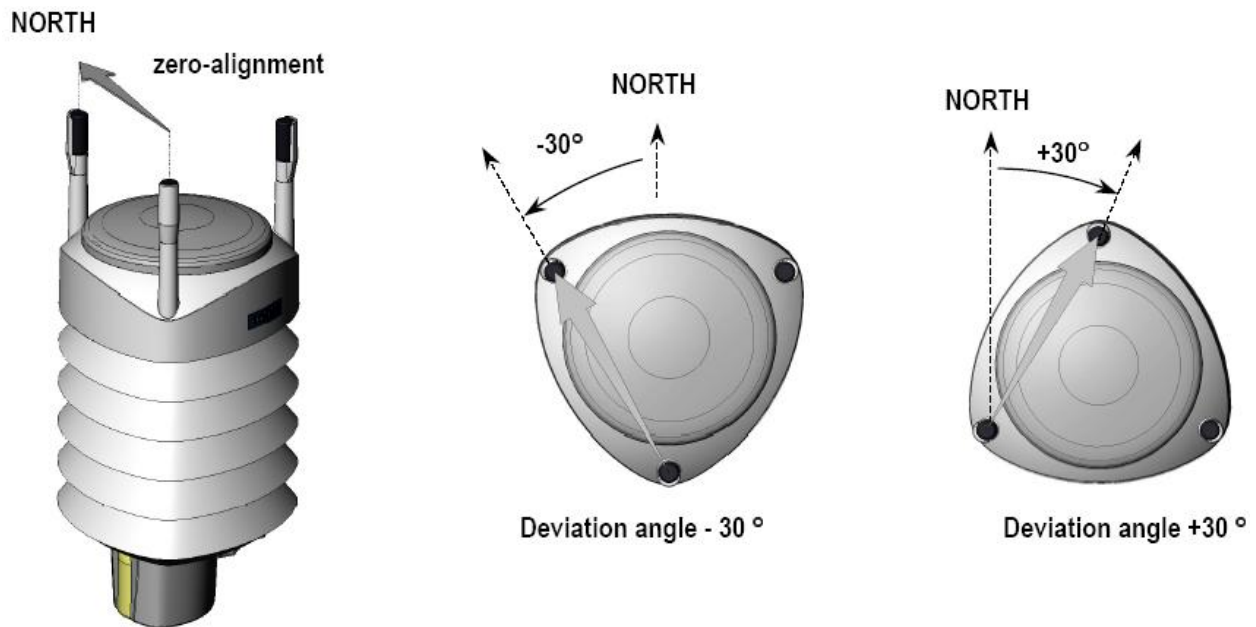

## 4 weatherVIC Software

### 4.1 About weatherVIC Software

NexSens weatherVIC software is a data collection and analysis tool for the Vaisala WXT510 multi-parameter weather system. It provides both a direct interface to the WXT510 and an interface to the NexSens iSIC Datalogger.

weatherVIC is a user-friendly software package that eliminates the complicated programming required to operate traditional dataloggers and sensors. Common sampling options such as log intervals, interrogation schedules, and units of sensor parameters are setup through easy to navigate dialog boxes and graphical menus. All data and sensor configuration settings are stored in a single database.

weatherVIC includes a unique historical report creation tool that can generate customized reports with data from the WXT510. While creating a report, users can include specific information about the monitoring site, location, sensors, and project along with the recorded measurements from instruments. After creation, reports can be converted to PDF, exported to Microsoft Excel or sent to a printer all with a single click of a button.

The following sections contain a quick walkthrough of weatherVIC's three main features – real time display, generating a historical data report, and graphical panel views. Please see the Reference Guide for a complete description of weatherVIC's features and functions.

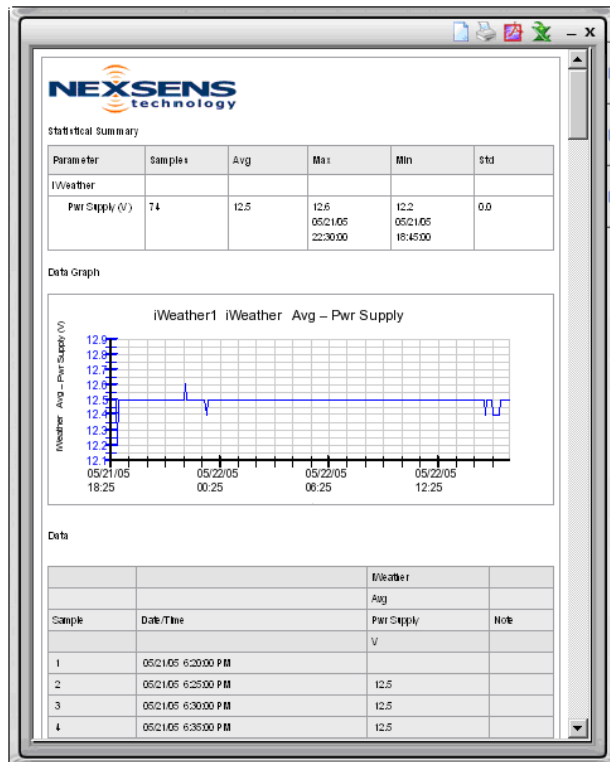
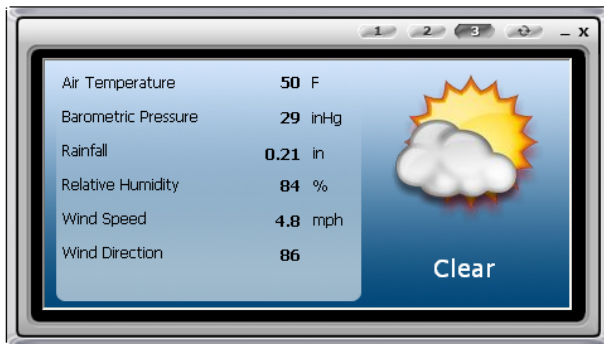

## 4.2 Running weatherVIC For The First Time

By default the weatherVIC icon is located on your desktop. Double click on this icon to open weatherVIC Software. The following screen will appear:



This is the **Virtual Instrument Control** screen. From this menu you can perform a variety of tasks as detailed on the following pages.

When you first open weatherVIC it will try to detect a WXT510 connected to any COM port on your PC. If it does not find one, the software will make you aware of this, and ask you if you would like to run in 'simulation mode'. If you click **Yes**, weatherVIC will open and replay data from a sample database. This database contains actual readings recording from a WXT510 device. Simulation mode gives you a way to view data and view the program without connecting a weather sensor.

Clicking **No** simply closes the program.



### 4.3 Getting Help and Software Updates

weatherVIC was designed to be as easy to use as possible, but if for any reason you need help, click the **Help** icon  and this user's guide will appear. From there you can search for your specific question or browse the program categories to narrow your search.

If Adobe Acrobat Reader is not installed, the manual will not be able to be opened. A copy of the reader is located on the weatherVIC CD in the Common Tools folder. The latest version can also be downloaded from <http://www.adobe.com/products/acrobat/readstep2.html> if your PC has an internet connection.

weatherVIC also allows you to easily keep up with software updates and new feature enhancements. From time to time NexSens will release a new version of software that adds new features and product enhancements.

Click on the slide panel on the main instrument control screen.



A side panel will slide out. This panel displays the current weatherVIC version and allows you to easily check for updates by simply clicking the **Check for Update** button. weatherVIC will check the NexSens website for a more up to date version of software. If you are running the latest version weatherVIC will let you know.

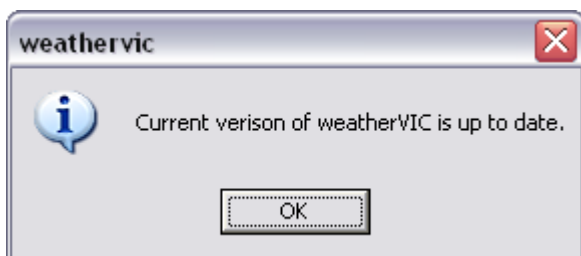

Otherwise it will ask you if you would like to update, and then begin to do so automatically.

## 4.4 Changing Sensor Configuration

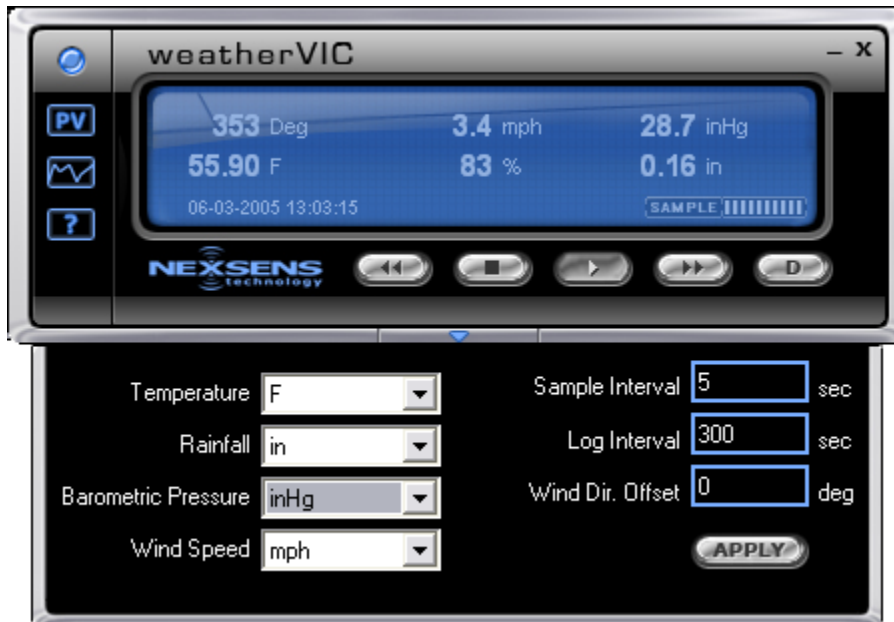

By clicking on the arrow located towards the bottom of the **Virtual Instrument Control** screen, a slide down dialog box will appear. This dialog box allows you to change the default sensor configurations. The unit of measurement for each parameter can be changed by selecting it from the drop down menu and clicking **Apply**.

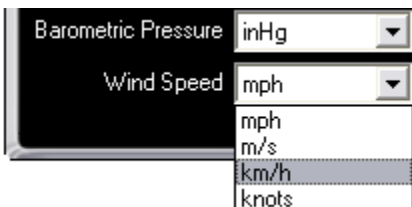

So if, for example, you would like to report Wind Speed in km/h instead of the mph; simply select km/h from the drop down menu and hit the **Apply** button. This change will reflect in all display readings and reports generated after clicking **Apply**.

In the **Sample Interval** field, enter the interval in seconds that you want to get a new reading from the WXT510. This reading will be updated on **Panel View** readings and the **Virtual Instrument Control** display window. The sample interval only affects display readings and data will not be saved into the weatherVIC database at this interval.

In the **Log Interval** field, enter the interval in seconds that you want to log data from the WXT510 into the weatherVIC database. This data will be saved and can then be used later to generate professional PDF or Excel reports.

The **Wind Direction Offset** is used in situations where the WXT510 could not be mounted facing in a Northwards directions. See *Chapter 2.3 Mounting* for more information.

## 4.5 Virtual Instrument Control View

The **Virtual Instrument Control** screen shows the current data readings and allows access to all other program views.



**Display** – Toggles which parameter is displayed on the main window. Each time you click this button a new parameter will be displayed until it reaches the screen that shows all parameters again.



**Slow** – Halves the sample and log interval. So if you had a sample and log interval of 5 seconds, this would be decreased to 10 seconds each.



**Stop** – Stops weatherVIC from sampling until the play button is pressed. Typically used if you plan to disconnect the WXT510 from the computer.



**Play** – Starts weatherVIC sampling again after the stop button has been pressed. Typically used after you reconnect the WXT510.



**Fast** – Doubles the sample and log interval. So if you had a sample and log interval of 10 seconds, this would be increased to 5 seconds each.

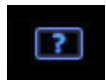

**Help** – Opens the windows help program. You can browse through topics and well as search for specific weatherVIC questions, all in a convenient indexed windows help program.

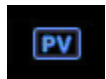

**Panel View** – Opens the weatherVIC panel view. This is a highly intuitive and graphical display of the current data.



**Report** – Opens the weatherVIC report view. This is a highly functional and powerful reporting module that allows you to easily export professional looking reports into PDF or Excel format. Simply select the parameters you wish to display, how you want to display them, and the interval you want to display and everything is automatically generated for you!

The sample interval will reflect in the sample icon:  When the bars are full a new reading will be displayed and the bars will start again at zero. This is a quick and efficient way to see how long until the next reading will be displayed on the screen.

## 4.6 Graphical Panel View

**PV** Clicking on the **Panel View** icon, located on the left side of the **Virtual Instrument Control** screen, opens up a graphical panel view representation of the WXT510 current readings. These readings will update as often as designated in the **Sample Interval**. See the previous section for more details.



There are three different panel views, each with its own unique look and features. Clicking on the  button will cycle through all three screens. A new screen will appear every 10 seconds.

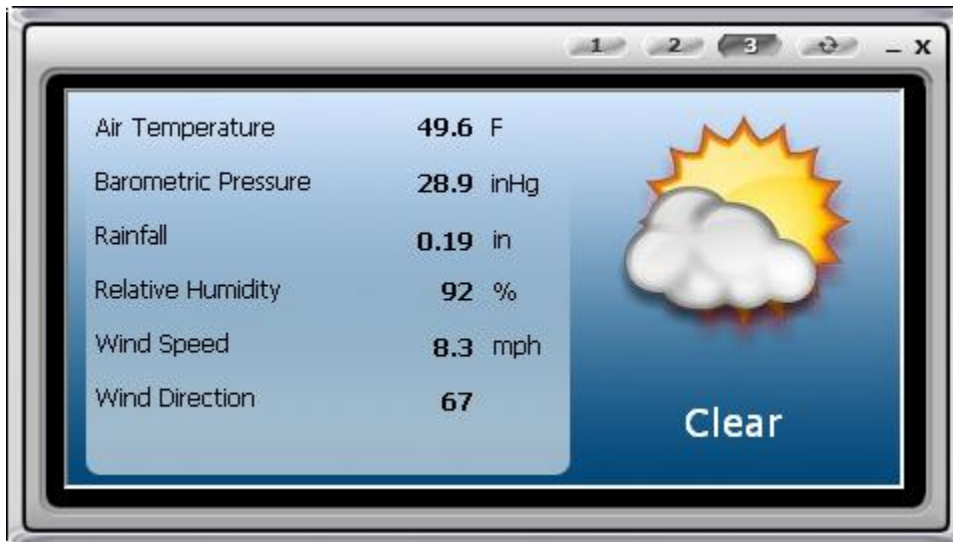

The screens are intelligent and will change based on the current weather conditions.



**Screen** – Either one, two, or three; opens Panel View screen one, two, or three.



**Cycle** – Cycles through the three Panel View screens.

## 4.7 Generate a Historical Data Report

 Clicking on the **Report** icon will open the weatherVIC report screen. The weatherVIC report feature is extremely powerful and has single-click to either Excel or PDF format.

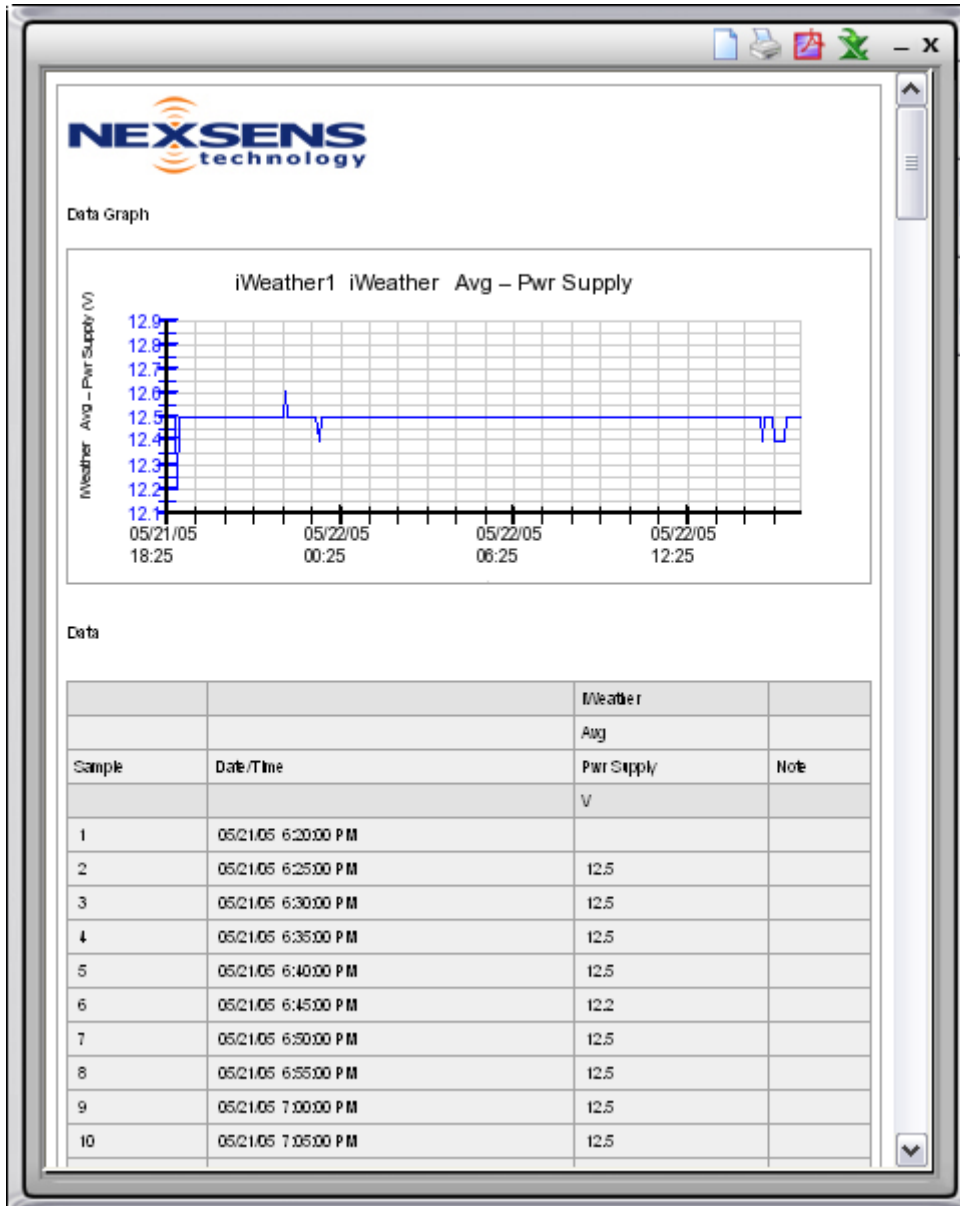

The three arrows on the side of the report screen open up dialog boxes that allow you to control what parameters are reported as well as how much of the data is shown. You can also edit how the graphs appear and what information is displayed. See the next few pages for a full description of weatherVIC reporting capabilities.

## 5 Working With Data

### 5.1 Report Tools

NexSens weatherVIC Software contains an advanced report generation component to help sort through the mountains of data collected from WXT510 weather sensors. To open the report screen click on the **Report** icon .

Data may be presented in one of three ways within a weatherVIC report – Statistics, Graph, and Table. In addition, users may also include information specific to the report such as the physical location of a sensor and name of the monitoring project. Users can choose which modes to include in a report – simply turn off the modes that you wish to hide.

Reports are created as HTML documents and may be saved locally in this format. In addition, reports can be exported to Microsoft Excel or converted to PDF and saved in a local folder.

Graphs are generated using GD. The GD license can be viewed online at: <http://www.boutell.com/gd/manual2.0.26.html#notice>

To configure a weatherVIC data report, use the integrated Report Tools. The Report Tools are spread across three tabs – General, Graph Properties, and Advanced.

### 5.2 Report Menu

The report menu allows you to export weatherVIC reports into other industry standard formats.

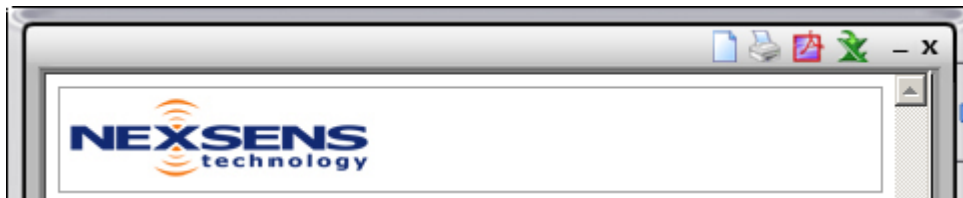

**Page Property** – Opens the page property dialog box.



**Print** – Sends the weatherVIC report to the printer.



**To PDF** - Exports the current report into a PDF file.

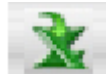

**To Excel** - Exports the current report data into a Microsoft Excel file.



**Navigation Panel** - Toggles the slide tabs on and off.

### 5.3 Page Property

Page Property allows you to setup features such as the paper size and other paper options. These features do not become displayed in weatherVIC and will only affect printing options. Click on the  icon to open the Page Property dialog box.

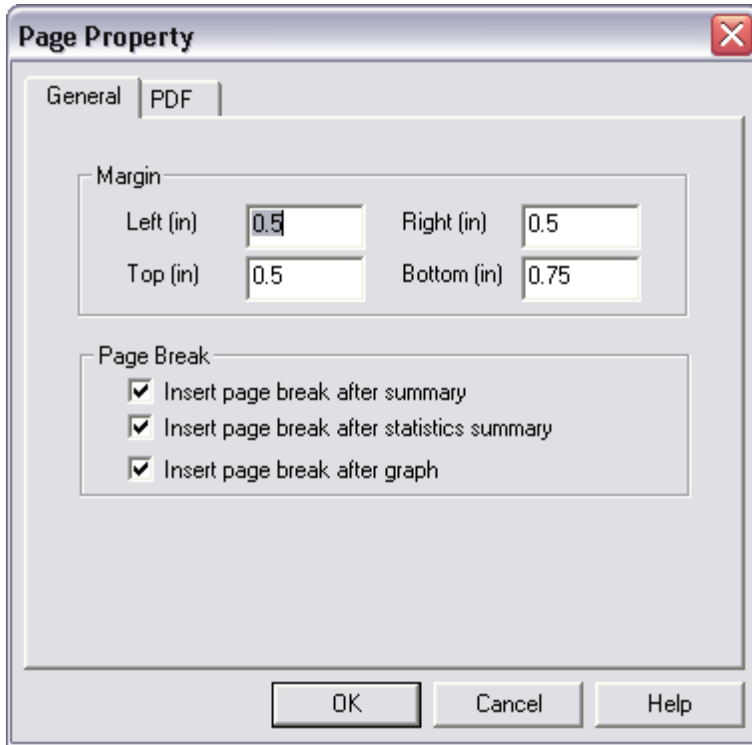

#### Margin

When in html view, weatherVIC will set the margins to the inches specified. This is just like margins set in Microsoft Word, etc. Margins should be chosen based on what looks the best on your printer.

#### Page Break

When in html view, weatherVIC will automatically insert page breaks after certain events as specified. This is just like the page break in Microsoft Word, etc. Using page breaks allows you to keep sections of the report on individual pages, and generally makes the report look better. All page break options are enabled by default.

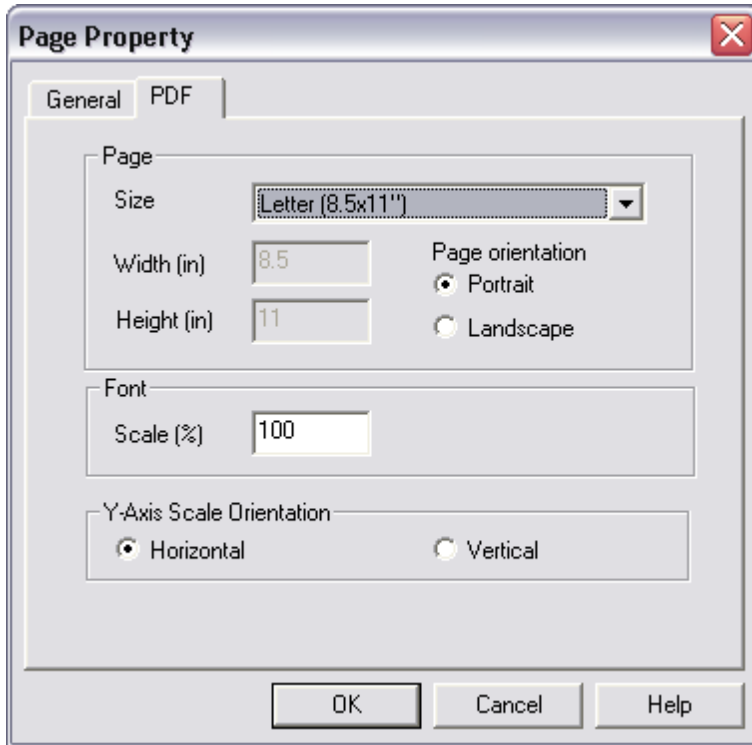

## Page

*Size* – Select the paper size you would like for PDF reports. This should be the actual size of paper you will be using to print the PDF report.

*Width / Height* – If **Custom** is selected from the **Size** drop down menu, you will be able to enter in the actual **Width** and **Height** of the paper you will be using to print your PDF report.

*Page Orientation* – Select the orientation you would like the pages of your PDF report to be printed.

## Font

*Scale* – Allows you to scale up or scale down the font size of your PDF report by the percentage entered.

## Y-Axis Scale Orientation

Sets the orientation of the Y-Axis scale labels on graphs generated in your PDF report.

## 5.4 General Tab

### Time Limit

*All* – Includes all data from the weatherVIC database in the report.

*Daily* – Includes all data from the selected day in the report.

*Monthly* – Includes all data from the selected month in the report.

*Yearly* – Includes all data from the selected year in the report.

*From To* – Includes all data between the selected dates in the report.

### Include

Reports generated by weatherVIC may include a project summary, data statistics, graphs, and data tables. Place a check in the boxes to include these components in the report.

*Summary* – Displays a user summary within the weatherVIC report.

*Statistics* – Displays a statistical summary for each parameter in the report. Includes number of samples, average value, minimum value, maximum value, and the standard deviation for each parameter.

*Graph* – Generates separate data graphs for each parameter and displays them within the weatherVIC report.

*Data* – Display data for each parameter in table format.

*Settings* – weatherVIC has advanced features in the **Report Header** menu. This menu can be accessed by clicking on the **Settings...** button. See the following page for more details.

### Time Resolution

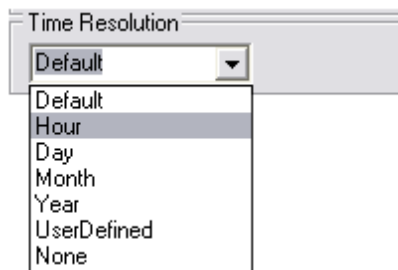

weatherVIC allows you to auto-align data based on time. This feature is very useful when generating reports using multiple sensors that do not necessarily have the same time interval between data points. By default, no data alignment is selected. If you would like to align data to minute intervals, simply select **UserDefined** and enter the number of minutes you would like to align the data to.

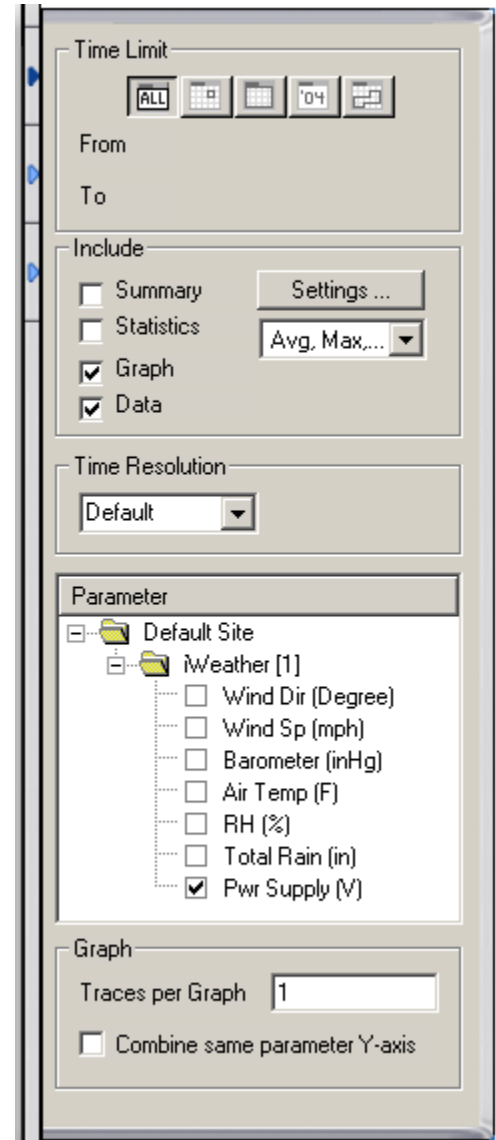

## Parameter

Place a check mark next to each parameter you want to include in the report. Reports can contain data from all parameters. By default, weatherVIC will not select any parameters. To display parameters, click the folder icon next to the device name and place a check next to the parameters you wish to view.

## Graph

weatherVIC incorporates an advanced feature allowing the user to place multiple traces on a single graph. This feature is very useful when comparing multiple parameters together to determine a correlation. Up to 12 traces per graph may be combined. weatherVIC will automatically place the y-axis onto the graph for each additional trace as well as re-color any traces to avoid two traces having the same color.

This feature is even further enhanced by the **Combine same parameter Y-axis** button. If there is a check next to this field then weatherVIC will combine the y-axis of each trace in the graph and redraw the trace as needed to fit this new y-axis.

## Settings

By clicking on the **Settings...** button a **Report Header** dialog box will open.

*Image* – Click on the **Browse** button to select a header image for weatherVIC reports. By default this image is the NexSens Logo.

The following information fills in the **Summary** field of each Report:

*Author* – the **Author** field is filled in with the text entered.

*Site* – the **Site** field is filled in with the text entered.

*Site Description* – the respective field is filled in with the text entered.

*Report Notes* – the respective field is filled in with the text entered.

*Show detail field note* – If you do not wish to see field notes on reports, uncheck this check box. This option is checked by default.

## 5.5 Advanced Tab

### Parameter

Select a parameter from the list to configure its advanced options. Changes made to one parameter will not affect the settings of any others. You can change multiple parameters by selecting the folder those parameters are in. Changes will then affect every parameter in that folder.

### Precision

Sets the number of decimal places for the data shown in statistics, graphs, and data table.

### Output

In the Summary, shows the value of the selected parameter during the time period defined in the Time Slice field in the General Settings..

*Avg* – Displays average value of the reported readings.

*Min* – Displays the minimum value that occurred.

*Max* – Displays the maximum value that occurred.

*Std* – Displays the standard deviation of the reported readings.

*Sum* – Displays the sum of all values the reported readings.

*Samples* – Displays the number of logged readings.

### Include Data

The Value Limit filters the data sets to be displayed in the report. A data set includes a date/time stamp, and the selected parameters from the General Settings tab of the Report Tools.

*All* – Display all data with no filtering.

$X \leq ?$  – Filter (Do Not Include) data sets above the indicated value.

$X \geq ?$  – Filter (Do Not Include) data sets below the indicated value.

$? \leq X \leq ?$  – Filter (Do Not Include) data sets outside the indicated values.

### Graph Markers

weatherVIC allows you to mark three time events on your graphical reports. Select the time and date from the **Mark Time** drop down menu and enter the text you would like displayed next to the mark in the **Mark Text** text box. This feature is extremely useful in marking times when the system was calibrated or offline for a period of time.

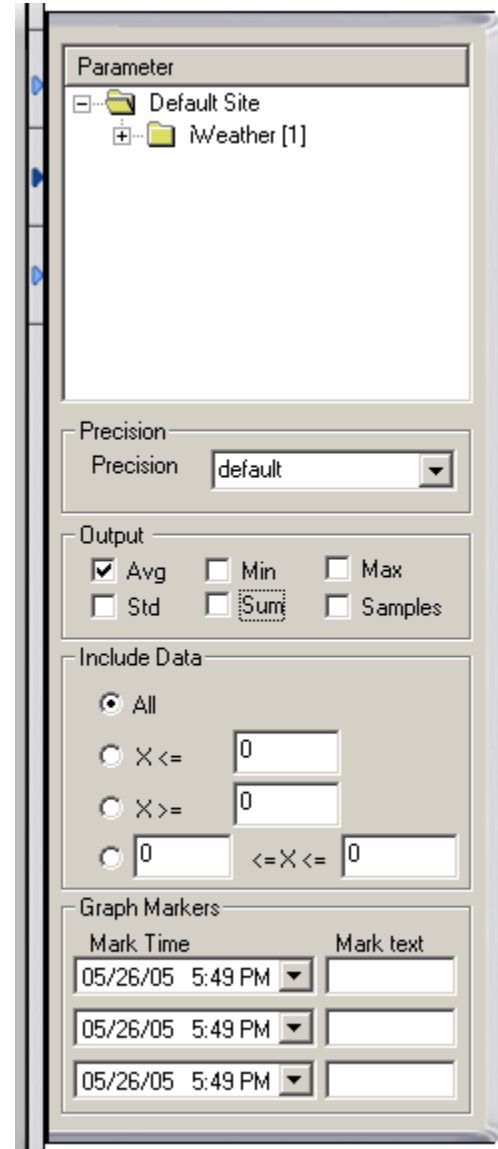

## 5.6 Graph Property Tab

### Parameter

Select a parameter from the list to customize its corresponding data graph. Graphs are configured independently from one another, and changes made to one graph will not affect the appearance of any others. Only parameters that have been checked in the General tab parameters list will show up here. You can deselect a parameter by un-checking its corresponding check box.

Note: If you would like to modify multiple parameters at a single time, you can select the folder they are in. Doing so will affect every device in that folder.

### Graph Scale

*Autoscale* – Enable auto-scaling of the graph for the selected parameter.

*Lower Limit* – Lower y-Axis limit for the graph of the selected parameter.

*Upper Limit* – Upper y-Axis limit for the graph of the selected parameter.

### Graph Appearance

*Back Color* – Background color for the graph of the selected parameter.

*Trace Color* – Trace color displayed on the graph of the selected parameter. Note: If multiple parameters are on a single graph then weatherVIC will make sure that two traces never have the same color. If you select a color for a trace that is already being used weatherVIC will automatically change the color of that trace.

*Grid Color* – Grid color displayed on the graph of the selected parameter.

*Trace Width* – Trace width on the graph for the selected parameter.

### Graph Property

Note: The first parameter from the **Parameter** menu must be selected. The text entered into these text boxes changes the text at the top of the report graphs. By default the **X Axis Label** is 'Date' and **Title line 1** is the name of your weatherVIC database.

The screenshot shows the 'Graph Property' dialog box. It is organized into four main sections:

- Parameter:** A tree view showing a folder structure with 'Default Site' and a sub-folder 'iWeather [1]'.
- Graph Scale:** Contains a checked 'Autoscale' checkbox, a 'Lower Limit' text box with the value '0', and an 'Upper Limit' text box with the value '100'.
- Graph Appearance:** Contains three color selection dropdowns: 'Back Color' (with a blue 'B' icon), 'Trace Color' (with a blue 'T' icon), and 'Grid Color' (with a blue 'G' icon). Below these is a 'Trace Width' text box with the value '1'.
- Graph Property:** Contains four text input fields: 'Title line 1', 'Title line 2', 'X Axis Label', and 'Y Axis Label'.

## **Appendix A: weatherVIC Quick Tutorial**

This weatherVIC Quick Tutorial is designed to be a quick look on how a weatherVIC system would be setup and used. This tutorial should demonstrate how simple and intuitive the weatherVIC system is.

A consulting firm needed a weather monitoring system that was cost effective, easy to use, and powerful. They also were limited on maintenance funding and staffing, and needed something that would not only save them time during the initial setup, but in the long run as well.

They chose the NexSens WeatherVIC, a complete system that fit their environmental needs. The NexSens WeatherVIC included:

- Vaisala WXT510 with fifty foot PC interface cable
- NexSens AC PowerPack
- NexSens weatherVIC Software

The WeatherVIC saved them time on initial installation; saved them time on viewing and monitoring data; saved them time on generating professional data reports for their clients; and saved them money as everything was included in a single system.

The next few pages detail their system and how they set it up in 10 easy steps.

### **WXT510 Installation**

#### **Step 1: Unpacking the WeatherVIC**

The group received the WeatherVIC box in the mail and began unpacking.

## Step 2: Preparing the Vaisala WXT510 for deployment

Still inside the office, the protective cap covering the Relative Humidity sensor was removed. This was accomplished in three easy steps:

1. A flat head screw driver was used to loosen the three fixing screws.
2. The top of the WXT510 body was gently pulled off of the body and the protective cap was removed.
3. Replace the top and tighten the three fixing screws that fasten the top to the bottom.

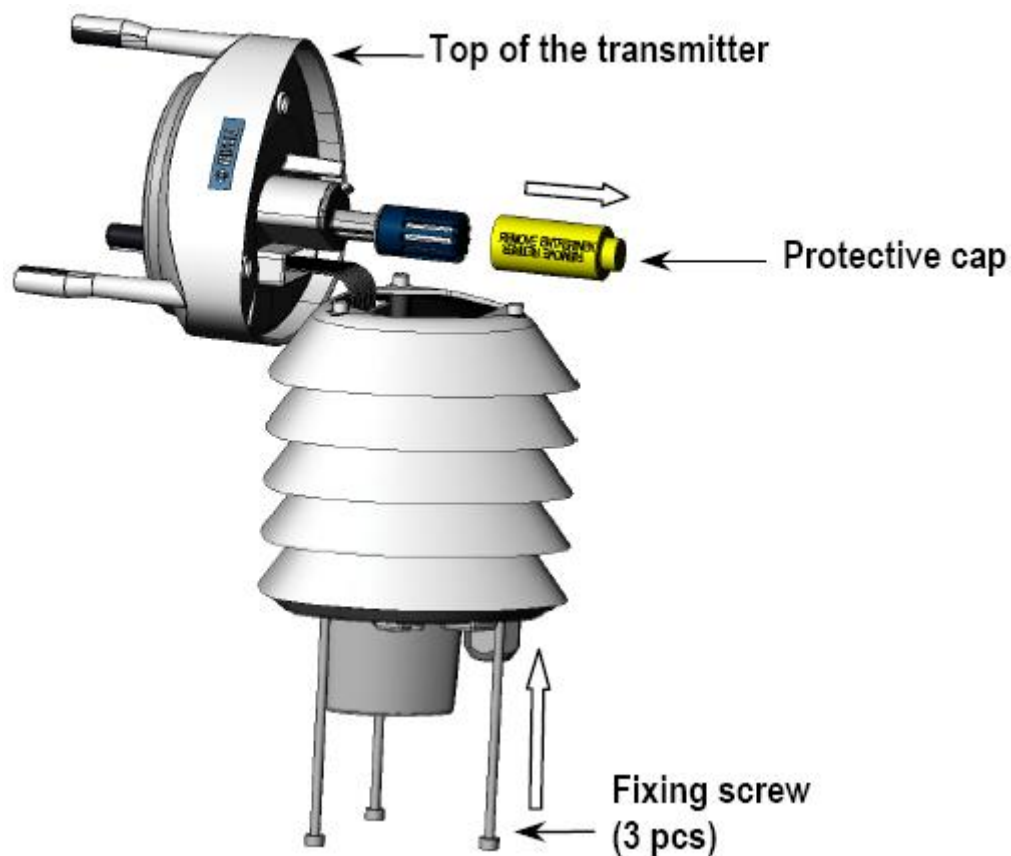

### Step 3: Mounting the Vaisala WXT510

The WXT510 was then taken outside to where a 1-3/8" aluminum pole had been mounted. This pole was purchased at a local hardware store, and had been buried a few feet in the ground a few days earlier.\*

The sensor was aligned to face in a northwards direction, and the fixing screw was tightened to prevent the unit from moving.

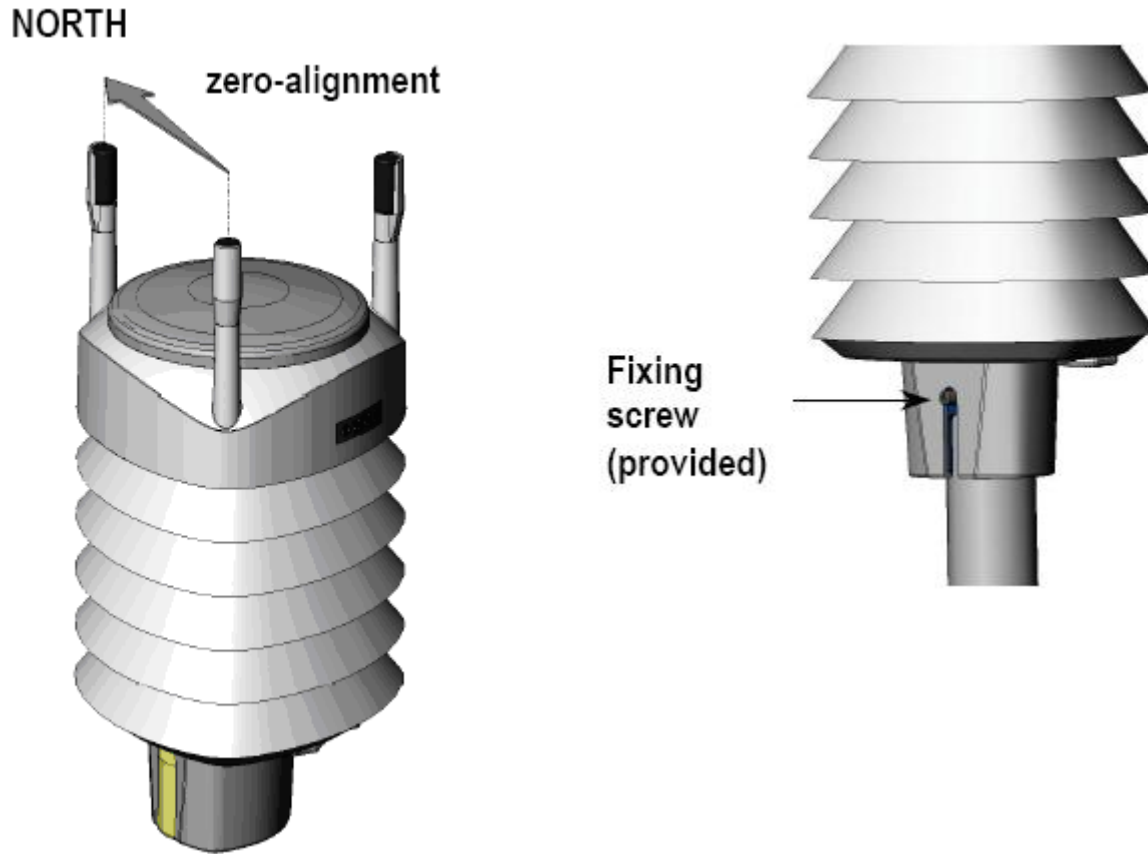

\*NOTE: the height of the pole should be determined by location; preferably a height that allows the WXT510 to be free from wind interference caused by nearby objects, such as trees or buildings. See *Section 2.3: Mounting* if you would prefer to mount the unit to a vertical pole mast.

### Step 4: Running the Cable

Once the WXT510 was affixed on top of the pole, the attached PC interface cable was fed through a hole into a room where a Windows computer was running. The group will later decide to run the cable underground through PVC or flex conduit to prevent the cable from being damaged.

## Running the Software

### Step 5: Installing the software

Back inside after a few short minutes installing the system, the weatherVIC CD was inserted into the computer and the group followed the windows dialog boxes to install the software.



Once installed, the weatherVIC icon was located on the desktop. When the software was first run it asked the group if they wanted to register the software or continue using the free trial for 30 days. weatherVIC software can be easily registered by phone, email or fax.

### Step 6: Connecting the Vaisala WXT510 to the PC

Once the software was installed, the group simply plugged in the weatherVIC AC PowerPack into a standard AC wall plug and connected the DB9 plug on the weatherVIC PC Interface Cable to a COM port on the back of their computer.

## Step 7: Running weatherVIC

The group started running weatherVIC. The WXT510 was automatically detected and programmed and the group immediately began seeing real time readings.



Deciding that they would rather see Wind Speed as kilometers per hour instead of miles per hour, they clicked on the arrow on the bottom of the screen and opened the configuration panel.

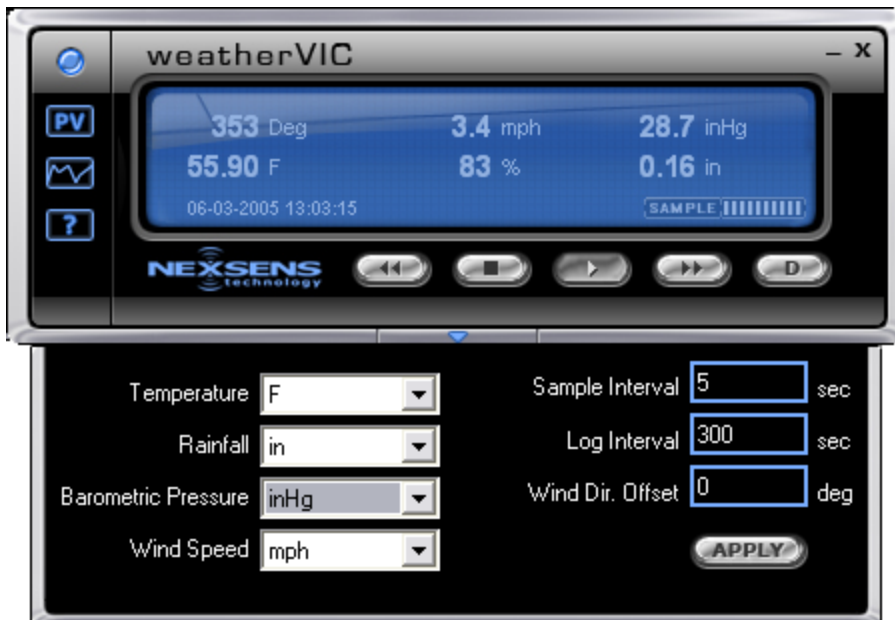

They changed the unit of measurement for Wind Speed by clicking on the drop down menu and selecting km/h. Clicking the **Apply** button finalized their selection.



### Step 8: Viewing and Monitoring Data

**PV** Clicking on the **Panel View** icon, located on the left side of the screen, the graphical panel view screen opened. There were three different screens to view, as well as a cycle screen that cycled through each of the previous three screens at ten second intervals.



These views allowed the group to monitor the real time data as well as get a quick forecast of the current weather conditions.

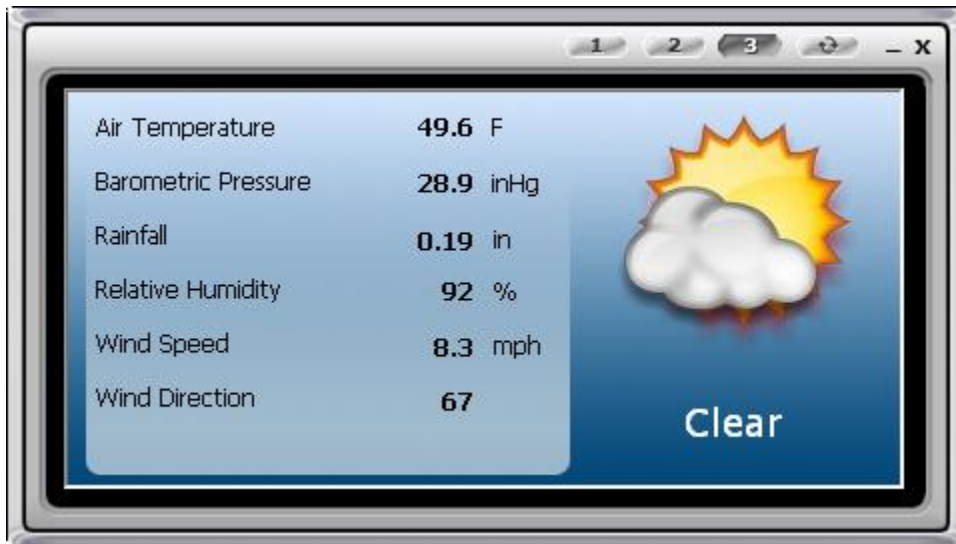

## Step 9: Generating Professional PDF Reports

After collecting data for a few days the group needed to give their client a report on the weather conditions over the past few days.

NexSens weatherVIC Software contains an advanced report generation component to help sort through the mountains of data collected from WXT510 weather sensors. Clicking on the report icon  opened this feature.

The report module automatically generated a report with graphs and data table for all weather parameters. Simply clicking the PDF icon on the top of the screen exported the report to a PDF document which was sent to the client. The report can be easily customized using the slide tabs located on the side of the screen. Once setup, the report will automatically regenerate every time it is opened. Simply open the report module, click the PDF or Excel icon, and you will have a professional report automatically generated for you. See *Chapter 4: Working with Data* for more information on how to customize the reports

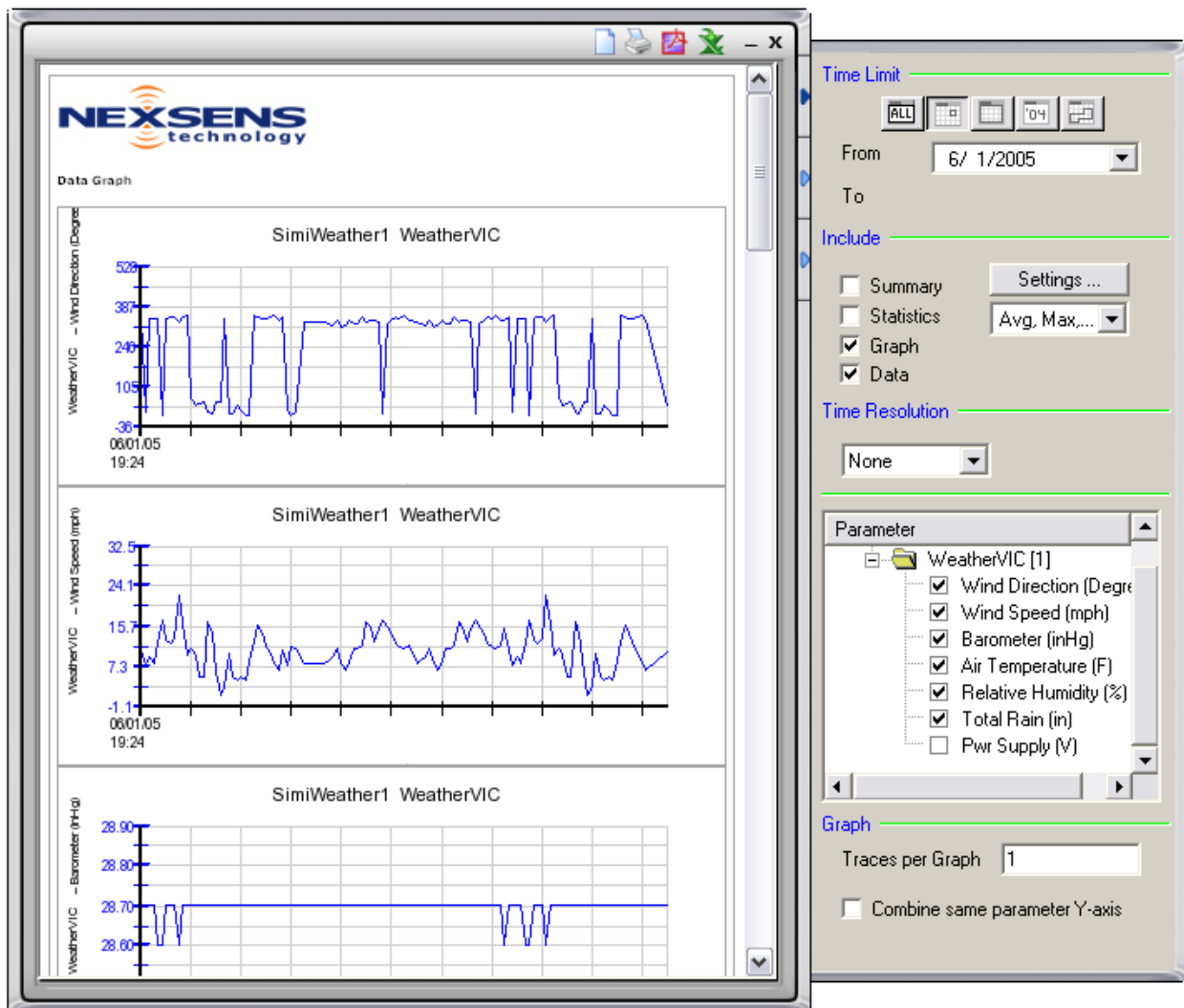

## **Step 10: Enjoying the Benefits**

The NexSens WeatherVIC was all setup and saved the consultants time and money. It can save you the hassle of complicated programming and in house resources by taking care of everything for you. If you have any questions regarding WeatherVIC and the weatherVIC product feel free to contact the NexSens Application Specialists.

Telephone: 1-937-426-2703

Email: [Info@NexSens.com](mailto:Info@NexSens.com)

Or visit us on the web: [www.NexSens.com](http://www.NexSens.com)

## Appendix B: Troubleshooting weatherVIC Display

Due to the highly graphical nature of weatherVIC software, some users may experience problems associated with the way weatherVIC is displayed on the screen.

### Report Text Improperly Displayed

No.	Date/Time	Avg	Avg	Avg	Avg	Avg	Avg	Avg
		WindDir	WindSp	BP	AirTemp	RH	TotalRain	Pwr Supply
		Degree	mph	inHg	F	%	in	V

Due to Windows settings the report fonts may be displayed in a skewed and unreadable manner. This problem can easily be corrected by right clicking on your desktop, causing a small drop down menu to appear. Select **Properties** from this list.

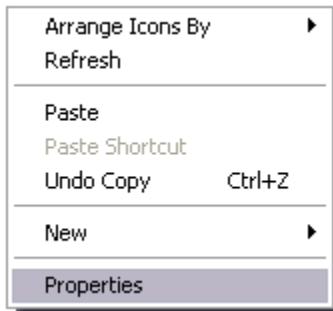

The **Display Properties** dialog box will appear. Click on the **Appearance** tab, and then the **Effects** button. The **Effects** dialog box will be displayed. Make sure that the **Use the following method to smooth edges of screen fonts:** is selected. It does not matter what is selected in the drop down menu, just that the box is checked.

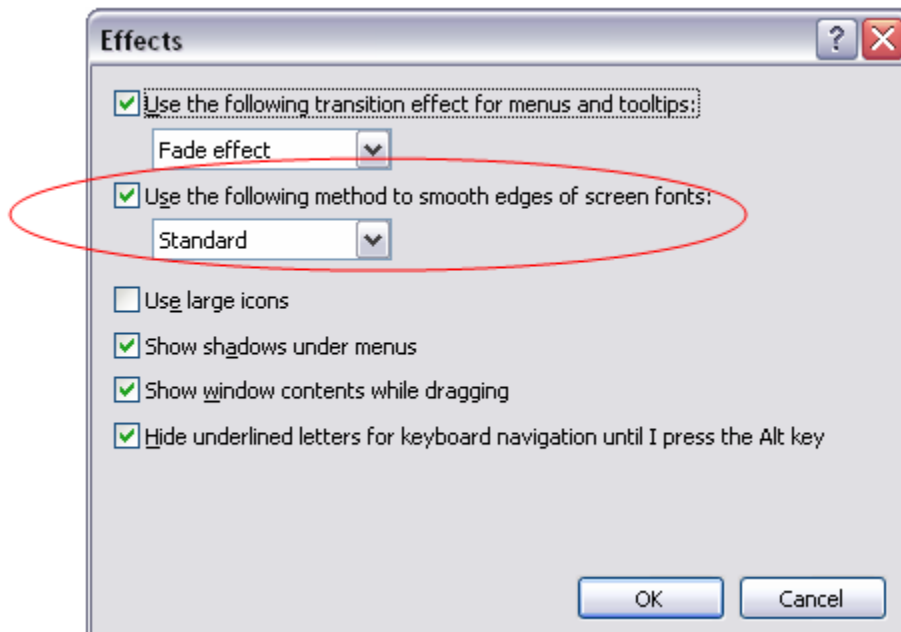

### Panel View Does Not Display Properly

Another possible problem is if the PC running weatherVIC does not have a Macromedia Flash Player installed. If the player is not installed then the panel view of weatherVIC will not be displayed properly.



If the PC is connected to the internet a Windows Security Warning dialog box will appear. It will ask you if you would like to install the latest version of Macromedia Flash Player. Click **Yes** and the flash player will be automatically installed.

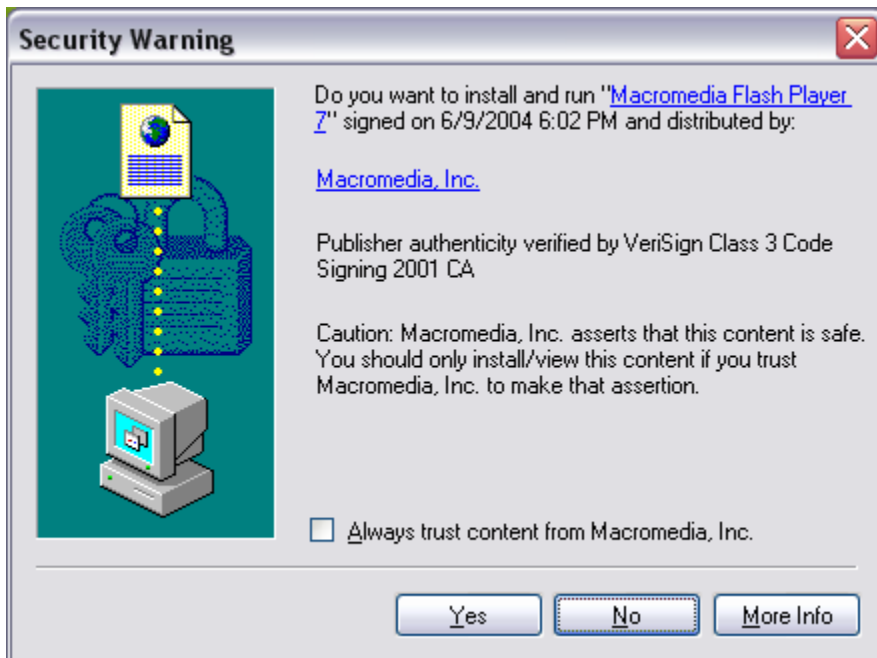

If the computer is not connected to the internet, this dialog box will not appear.

Alternatively, Macromedia Flash Player can be downloaded here: <http://www.macromedia.com/>

## ActiveX Controls Disabled

This behavior can occur if your current security settings prohibit downloading signed ActiveX controls. The error message will say: “**Your current security settings prohibit running ActiveX controls on this page. As a result, the page may not display correctly**” or “**Please wait for page to download completely before performing this task.**”

To resolve this issue, follow these steps.

### Internet Explorer 5.0

1. On the **Tools** menu in Internet Explorer, click **Internet Options**.
2. On the **Security** tab, click **Internet**.
3. Click **Default Level**, and then click **OK**.

If the issue continues to occur, follow these steps:

1. On the **Tools** menu in Internet Explorer, click **Internet Options**.
2. On the **Security** tab, click **Internet**, and then click **Custom Level**.
3. Under **Download Signed ActiveX Controls**, click **Enable** or **Prompt**.
4. Click **OK**, and then click **Yes**.
5. Click **OK**.

If the issue continues to occur, reinstall Internet Explorer from the following Microsoft Web site:  
<http://www.microsoft.com/windows/ie/>

### Internet Explorer 4.0

1. On the **View** menu in Internet Explorer, click **Internet Options**.
2. Click the **Security** tab.
3. In the **Zone** box, click **Internet Zone**, and then click **Reset**.
4. Click **OK**.

If the issue continues to occur, follow these steps:

1. On the **View** menu in Internet Explorer, click **Internet Options**.
2. Click the **Security** tab.
3. In the **Zone** box, click **Internet Zone**.
4. Click **Custom (For Expert Users)**, and then click **Settings**.
5. Under **Download Signed ActiveX Controls**, click **Enable** or **Prompt**.
6. Click **OK**, and then click **OK** again.

If the issue continues to occur, reinstall Internet Explorer from the following Microsoft Web site:  
<http://www.microsoft.com/windows/ie/>