

# T-Node

Water  
Temperature  
Sensor

## User Manual



## About NexSens

NexSens Technology, Inc. was founded in the late 1990s with a mission to advance the capabilities and simplify the development of environmental monitoring systems. The company specializes in environmental sensors, remote data acquisition and communications technology, easy-to-use computer software, and web based datacenters.

iChart Software is an easy-to-learn, easy-to-use Windows-based software program designed to interface with the industry's most popular environmental monitoring sensors and systems. A large multi-vendor instrument library makes setup quick and easy. iChart automates much of the tedious programming, data collection, and manual data processing common with other environmental data collection systems.

The SDL500 (Submersible Data Logger) and iSIC (Intelligent Sensor Interface and Control) are state-of-the-art data loggers that simplify the collection of real-time data from environmental sensors and monitoring instruments. The data loggers support multi-vendor sensor connections and are specifically designed for environmental data monitoring.

WQData PRO is an enterprise class and business critical web-based software solution for environmental data management. It assists with collecting, storing, analyzing, interpreting, sharing, and publishing environmental data. The datacenter effectively manages a wide variety of biological, physical, and chemical parameters, along with many other environmental observations and project information.

WQSensors smart USB-based sensors include: Temperature, pH, ORP, Dissolved Oxygen, Ammonium, Bromide, Calcium, Chloride, Fluoride, and Nitrate. An integral USB connector on the sensor cable offers a simple, hassle-free connection to a computer without the need for a meter or batteries.

T-Node temperature systems, based on sensorBUS technology, provide a simple, yet effective, plug-and-play solution for developing multi-sensor networks and temperature strings. sensorBUS was developed to replace, expand, and enhance centralized parallel wiring for prevailing analog and digital signal transmissions. With integral 1-wire, SDI-12 and RS-485 interfaces, sensorBUS provides versatile sensor networking capability.

Monitoring Buoys are designed to support offshore monitoring systems. These buoys provide a robust floating platform for inland water monitoring projects.

NexSens products and systems simplify the setup and operation of environmental monitoring networks and help ensure quality data.

# Table of Contents

<b>Overview .....</b>	<b>1</b>
<b>What's Included .....</b>	<b>2</b>
Common Accessories .....	2
<b>Specifications.....</b>	<b>3</b>
General.....	3
Temperature .....	3
<b>Factory Calibration .....</b>	<b>4</b>
Calibration Records .....	4
Determination of Coefficients.....	4
<b>Getting Started .....</b>	<b>5</b>
Single-Point Temperature String Assembly.....	5
Multi-Point Temperature String Assembly.....	6
Connecting to an SDL500 Data Logger .....	8
Connecting to an iSIC Data Logger.....	8
Pre-Deployment Check.....	9
<b>Connector Signals .....</b>	<b>11</b>
<b>Maintenance .....</b>	<b>12</b>
Cleaning .....	12
Storage.....	12
<b>Calibration .....</b>	<b>12</b>
<b>Troubleshooting.....</b>	<b>13</b>
<b>Warranty and Service .....</b>	<b>14</b>

## Overview

The NexSens T-Node water temperature sensor utilizes a digital sensor secured in a protective housing for underwater deployments in fresh, brackish, or seawater. The sensors can be connected in series using UW underwater cables and suspended vertically in a water column or horizontally along a stream or riverbed. Double o-rings (both gland and face seals) ensure a reliable and watertight connection.

Temperature data is transmitted on the 1-wire bus. Additionally, the T-Node offers pass-through signals for SDI-12 and RS-485, allowing the user to connect other environmental measurement sensors along the string. This sensorBUS architecture has been designed so researchers can easily build and customize multi-point sensor strings and environmental monitoring networks.

T-Node sensors feature a plug-and-play interface to NexSens SDL500 submersible data loggers, which can be housed within a floating data buoy platform. The SDL500 can collect data internally as a standalone unit, or it can come equipped with a radio or cellular telemetry modem for continuous, real-time monitoring.

For interface to SCADA (Supervisory Control and Data Acquisition) systems or data loggers that do not support the 1-wire bus, a NexSens data logger can be configured as a slave to interface with other equipment.



## What's Included

Each T-Node Water Temperature Sensor includes a certificate of calibration card. UW underwater plugs are also included as required for temperature string terminations.

## Common Accessories

**Table 1:** Accessories commonly used with T-Node temperature sensors

**NOTE**  
The T-Node uses unique NexSens UW Underwater Connectors for interfacing with accessories.

section consisting of temperature sensors and underwater cables

<b>Part Number</b>	<b>Description</b>	<b>Details</b>
<b>UW</b>	Underwater cable	Used for assembling T-Node temperature strings, various lengths available
<b>UW-A</b>	Underwater armored cables	Underwater cables with anti-chafing armor
<b>T-Boost</b>	1-Wire signal booster	Used for increasing the length limit and sensor capacity of a single temperature string
<b>MS8-TNODE</b>	Underwater to MS8 cable adapter	Used to connect T-Node temperature sensor to a NexSens iSIC data logger
<b>T-Clamp</b>	T-Node mooring clamp	Used to secure T-Node strings along a mooring line
<b>SS187</b>	Stainless steel mooring line	Used for buoy and sensor mooring systems
<b>UW-2W</b>	sensorBUS signal splitter	Used for adding an SDI-12 or RS-485 sensor at any position along a temperature string

# Specifications

## General

**Table 2:** NexSens T-Node temperature sensor general specifications

<b>Length</b>	5.3 in (134.6 mm)
<b>Diameter (OD)</b>	1.4 in (35.6 mm)
<b>Weight</b>	0.3 lbs
<b>Housing</b>	Acetal Copolymer Polyvinylchloride (PVC)
<b>Operating Temp Range</b>	-25 to 75°C
<b>Operating Depth Range</b>	100 m
<b>Sensor Capacity</b>	50 nodes
<b>Output</b>	1-Wire
<b>sensorBUS Signals</b>	SDI-12, RS-485
<b>Power Requirements</b>	Voltage: 3.5 to 5.75 VDC
<b>Power Consumption</b>	4 mA processing <1 mA idle

## Temperature

**Table 3:** NexSens T-Node temperature sensor temperature specifications

<b>Range</b>	0 to 50°C
<b>Accuracy</b>	±0.1°C
<b>Resolution</b>	0.01°C
<b>Unit of Measure</b>	Celsius

# Factory Calibration

## Calibration Records

Each T-Node uses a bandgap-based digital temperature sensor subject to a precision factory calibration for NIST (National Institute of Standards and Technology) traceable temperature measurements. Calibration data remains stored at the factory and is presented to the end-user in the form of a calibration card provided with each temperature sensor. Records can be referenced via the serial number engraved on each sensor (See Figure 2).



Figure 2: T-node temperature sensor

## Determination of Coefficients

Quadratic equations unique to each temperature sensor are employed to ensure sensor accuracies of ±0.1°C. Coefficients a, b, and c are determined from a stepwise calibration process over a 50 to 0°C temperature range. Readings are then verified for accuracy by reversing the calibration procedure and analyzing the resulting data sets.

**NOTE**  
Temperature reading conversions from°C take place in iChart software following data collection temperature measurement processing.

	T-Node Certificate
<p>T-Node S/N: <b>1303</b>          1-Wire ID: CC000002446EF628          Coefficients (ax<sup>2</sup>+bx+c):              a= 2.66746588749811E-4              b= -1.9184529781341601E-2              c= 0.26979818940162698</p>	
<p>Manual: <a href="http://www.nexsens.com/knowledgebase/manual.htm">http://www.nexsens.com/knowledgebase/manual.htm</a></p>	

Figure 3: T-node calibration card

## Getting Started

### Single-Point Temperature String Assembly

Single-point strings are used to determine water temperature at one location, typically at the surface.

To assemble a single-point temperature string, first connect the male UW plug connector on the T-Node to the female UW receptacle connector on an Underwater Cable as in Figure 4.

#### NOTE

Always check *each* mating connector for an o-ring before securing any UW underwater connection.

#### WARNING

All o-rings must be clean and dry before being used to secure watertight connections.



Figure 4: Underwater connection between T-node sensor and UW cable

Then connect the supplied UW underwater plug to the female UW receptacle connector on the T-Node to terminate the string as shown.



Figure 5: UW Underwater Plug

## Multi-Point Temperature String Assembly

Multi-point strings are used to determine temperature at various locations. Typically of interest are temperature distributions vertically in a water column or horizontally along a stream or riverbed.

**NOTE**  
Always check each mating connector for an o-ring before securing any UW underwater connection.

During the assembly of a multi-point temperature string, the nodes should be organized by serial number, with the first node being placed at some known reference point (usually closest to the water’s surface for vertical strings). This helps keep the T-Nodes in order in NexSens Chart software, which automatically recognizes and displays temperature string data according to sensor serial numbers, from lowest number to highest. Thus, ordering the T-Nodes by serial number in the field results in the display of an organized temperature profile with no post-deployment programming hassles.

Sometime the order of the serial numbers must be modified following automatic detection. For example an additional node may be added to the string at an intermediate depth or a newer replacement node may be needed. In this case, simply select a serial number from the list and click **Move Up** or **Move Down** to change the order.

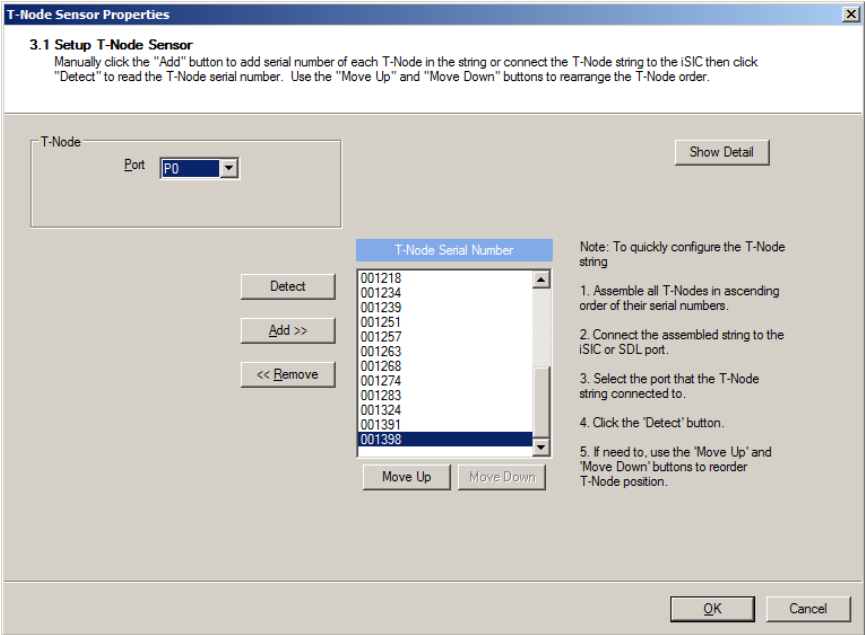

Figure 6: After clicking **Detect** each temperature element in a T-Node string is automatically detected and ordered by serial number in iChart software

Temp00 (C)	20.59
Temp01 (C)	20.51
Temp02 (C)	20.36
Temp03 (C)	20.59
Temp04 (C)	20.51
Temp05 (C)	20.70
Temp06 (C)	20.32
Temp07 (C)	20.01
Temp08 (C)	20.16
Temp09 (C)	20.25
Temp10 (C)	20.16

Turn ON live data   Setup...   Schedule...   Interrogate

Figure 7: Typical temperature data display in iChart, organized by serial number

## WARNING

All o-rings must be clean and dry before being used to secure watertight connections.

To begin assembling a multi-point string, first gather all T-Nodes and Underwater Cables. Set the components out on a clean table or lab bench.

Select a single underwater cable as the first component in the temperature string, and connect it to the UW plug end of the T-node with the lowest serial number (see Figure 5).

Continue the assembly with another underwater cable. Attach the plug end of the second cable to the receptacle end of the first T-Node in the string.

Proceed with additional T-Node sensor attachments, each followed by an underwater cable. Be sure to keep track of variations in underwater cable lengths if non-uniform spacing is desired. Also make sure to terminate the string with the supplied UW underwater plug.

## Connecting to an SDL500 Data Logger

UW underwater connectors provide a plug-and-play interface for connection to NexSens SDL500 Submersible Data Loggers.

The SDL500 sensor bulkhead includes sensor connection ports identified as T, P1, P0, A and D.

### NOTE

A T-boost is required for temperature strings that have less than 14 T-Node temperature elements and/or a total length less than 15 meters.

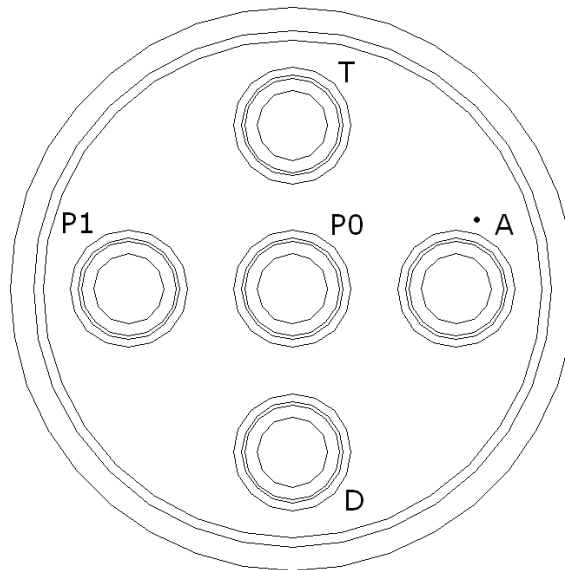

**Figure 8:** SDL500 sensor bulkhead

For temperature strings that have less than 14 T-Node temperature elements and/or a total length less than 15 meters, connect to **Port T** on the SDL500 sensor bulkhead.

All other temperature strings require the use of a T-Boost Signal Booster. In such cases, connect the T-Boost directly to **Port P0** on the SDL500 sensor bulkhead, and then connect the temperature string to the signal booster.

Signal boosters require 12 to 16 VDC power to operate. To accommodate this, SDL data loggers with long temperature strings that require a T-boost must use internal batteries even when the data logger is connected to a computer via the SDL USB interface cable.

## Connecting to an iSIC Data Logger

T-Node sensors can be connected to any iSIC data logger using the 1-Wire UW to MS8 Adapter.



**Figure 9:** MS8-TNODE adapter

First plug the temperature string into the adapter's UW connector. Then attach the MS8 connector from the adapter to the mating MS8 port on the iSIC enclosure.

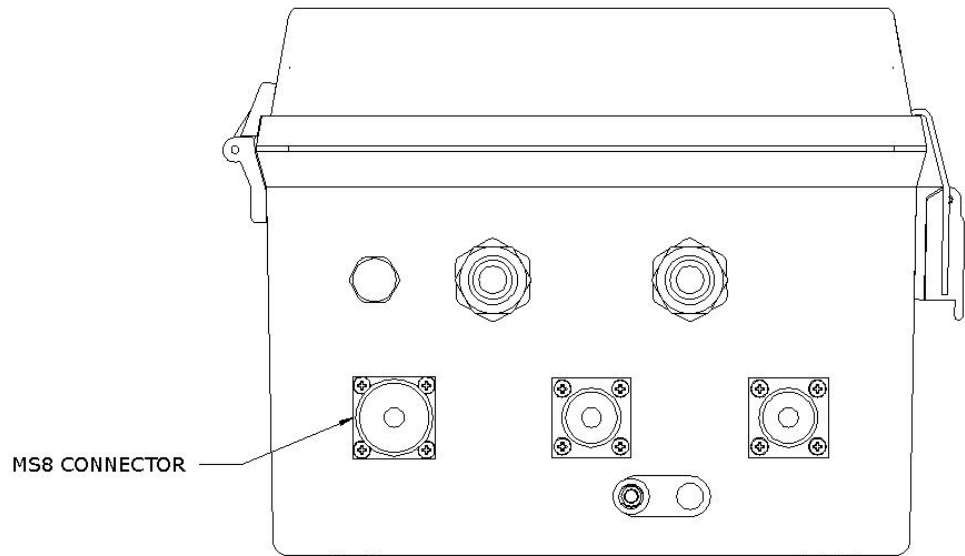

**Figure 10:** iSIC data logger enclosure (bottom view)

## **Pre-Deployment Check**

It is recommended that field deployments be carefully planned, and it is best to completely configure the system on a lab bench and test it for a period of time prior to taking it to the field. This will ensure a successful deployment and quality data collection. Additionally, it is much easier to troubleshoot problems in the lab rather than in the field

For *SDL500 Submersible Data Logger* applications, connect the data logger to a PC via the SDL500’s supplied USB interface cable.

For *iSIC Data Logger* applications, first ensure that power is supplied to the device. Then connect to the PC via the direct connect serial cable.

With iChart software running, select **File | New Project**. Name the project and follow the step-by-step procedure in the **Setup Device Wizard**. Refer to the iChart manual for additional information.

**NOTE**  
Recall that iChart automatically detects T-Node serial numbers and orders them sequentially from lowest to highest; the software does not detect temperature sensor position along a string directly.

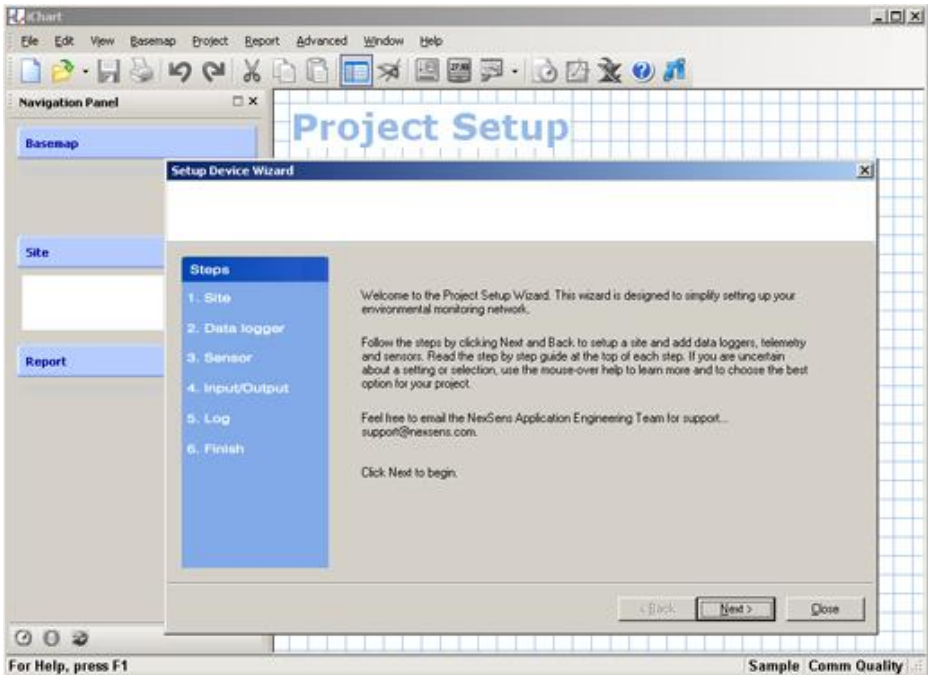
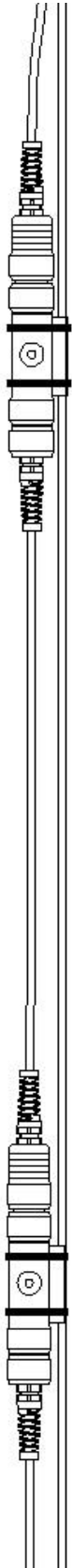

Figure 11: iChart software setup device wizard

## Setting Up a Sensor Mooring Line

Temperature strings are frequently attached to a mooring line to keep them fixed in place vertically within a water column. This technique helps to ensure that temperature data is consistently being monitored at the desired depths.

With the temperature string laid out on a flat surface, secure to the sensor mooring line to each T-Node using T-Clamp sensor mooring clamps and plastic cable ties.



**Figure 12:** Stainless steel mooring line (left) and T-clamp sensor mooring clamp (right)

## Connector Signals

T-Node sensors require three signals for operation; +5 VDC, Ground, and 1-Wire. The sensorBUS protocol used by T-Node strings can also carry SDI-12 and RS-485 signals, which are available for connecting other sensors along a sensor string.



**Figure 14:** T-node UW-plug end

**Table 4:** UW-plug end signal pinout

Pin	Signal
1	N/A (Not Connected)
2	Ground
3	1-Wire data
4	+5 VDC
5	+12 VDC
6	SDI-12
7	Sensor RS-485B
8	Sensor RS-485A

**Figure 13:** T-Node string on sensor mooring line

## Maintenance

There is very little maintenance required for T-Node temperature strings, because they are designed for long term deployments in submersible applications.

### Cleaning

Any bio-fouling that accumulates on T-Node temperature strings during deployments should be cleaned using a soft cloth or soft-bristled brush along with soap and water.

### Storage

T should be stored in a cool, dry place.

### Calibration

Although T-Nodes are capable of holding the initial factory calibration indefinitely, NexSens recommends that temperature strings be sent in for a factory recalibration every two years to ensure maximum sensor performance.

#### **WARNING**

**Never allow moisture to enter any of the UW connectors during cleaning.**

## Troubleshooting

Follow the procedure below to isolate and resolve sensor interface problems.

**Table 5:** Solutions to common problems with T-Node temperature sensors

Symptom	Possible Cause	Corrective Action
Temperature data is displayed as a value between -99999 and -100001	Leakage into a connector	Check each underwater connection for flooding
	String disconnected (or severed cable)	Check the physical setup and condition of the temp string
Temperature Readings appear as 85°C	Temp string power cut off, not supplied, or shorted to ground	Check system power connections for proper wiring and adequate voltage
Data is displayed as +555.5	Moisture in a connector	Dry the connector
iChart can not detect (or intermittently detects) temp string	The string is too long (more than 14 T-Node temperature elements and/or a total length greater than 15 meters)	Add a T-boost Signal Booster in line with the temp string

If the issue persists, visit [www.NexSens.com](http://www.NexSens.com) to search the Knowledge Base for FAQs and troubleshooting guides; otherwise please contact NexSens technical support.

## Warranty and Service

NexSens Technology, Inc. warrants products against defects in materials or workmanship for a period of 12 months from the date of delivery to the original customer. This warranty is limited to the replacement or repair of such defects, without charge, when the product is returned to NexSens Technology, Inc. Damage due to accidents, misuse, tampering, lack of reasonable care, loss of parts, failure to perform prescribed maintenance, or accidents of nature are not covered. This warranty excludes all other warranties, express or implied, and is limited to a value not exceeding the purchase price of the instrument.

### Limitation of Warranty

This warranty is not applicable to any NexSens Technology, Inc. product damage or failure caused by (i) failure to install, operate or use the product in accordance with NexSens Technology, Inc. written instructions, (ii) abuse or misuse of the product, (iii) failure to maintain the product in accordance with NexSens Technology, Inc. written instructions, (iv) any improper repairs to the product, (v) use by you of defective or improper components or parts in servicing or repairing the product, or (vi) modification of the product in any way not expressly authorized by NexSens Technology, Inc.

Corporate Headquarters and Authorized Service Center

NexSens Technology, Inc.  
1415 Research Park Drive  
Beavercreek, Ohio 45432  
Phone 937.426.2703 • Fax 937.426.1125  
E-Mail [support@nexsens.com](mailto:support@nexsens.com)

**Revision:** 02      **Revision Date:** November 15, 2010

**WARNING**  
NexSens Technology, Inc. products are not authorized for use as critical components in any life support system where failure of the product may affect its safety or effectiveness.



1415 Research Park Drive  
Beavercreek, OH 45432  
937-426-2703  
[www.NexSens.com](http://www.NexSens.com)