

MB-300/400

Data
Buoys

User Manual



About NexSens

NexSens Technology, Inc. was founded in the late 1990s with a mission to advance the capabilities and simplify the development of environmental monitoring systems. The company specializes in environmental sensors, remote data acquisition and communications technology, easy-to-use computer software, and web based datacenters.

iChart Software is an easy-to-learn, easy-to-use Windows-based software program designed to interface with the industry's most popular environmental monitoring sensors and systems. A large multi-vendor instrument library makes setup quick and easy. iChart automates much of the tedious programming, data collection, and manual data processing common with other environmental data collection systems.

The SDL500 (Submersible Data Logger) and iSIC (Intelligent Sensor Interface and Control) are state-of-the-art data loggers that simplify the collection of real-time data from environmental sensors and monitoring instruments. The data loggers support multi-vendor sensor connections and are specifically designed for environmental data monitoring.

WQData PRO is an enterprise class and business critical web-based software solution for environmental data management. It assists with collecting, storing, analyzing, interpreting, sharing, and publishing environmental data. The datacenter effectively manages a wide variety of biological, physical, and chemical parameters, along with many other environmental observations and project information.

WQSensors smart USB-based sensors include: Temperature, pH, ORP, Dissolved Oxygen, Ammonium, Bromide, Calcium, Chloride, Fluoride, and Nitrate. An integral USB connector on the sensor cable offers a simple, hassle-free connection to a computer without the need for a meter or batteries.

T-Node temperature systems, based on sensorBUS technology, provide a simple, yet effective, plug-and-play solution for developing multi-sensor networks and temperature strings. sensorBUS was developed to replace, expand, and enhance centralized parallel wiring for prevailing analog and digital signal transmissions. With integral 1-wire, SDI-12 and RS-485 interfaces, sensorBUS provides versatile sensor networking capability.

Monitoring Buoys are designed to support offshore monitoring systems. These buoys provide a robust floating platform for inland water monitoring projects.

NexSens products and systems simplify the setup and operation of environmental monitoring networks and help ensure quality data.

Table of Contents

Overview	1
Typical Configurations	2
Single-point Mooring	2
Two-point Mooring	2
What's Included	3
Common Accessories	3
Specifications.....	5
Getting Started	6
Tower Assembly	6
Solar Power Pack Assembly	7
Beacon Assembly	9
Pre-deployment Test	10
Install and Power the Data Logger	11
Connect Sensors	12
Confirm Data Collection & Transmission.....	13
Prepare for Deployment	13
Setup the Sensor Mooring Line.....	14
Safely Deploy the Buoy	15
Prepare Buoy & Anchor Lines.....	16
Attach Buoy & Anchor Lines	17
Install Data Logger & Sensors	18
Maintenance	21
Post-Season Cleaning & Storage	21
Warranty and Service	22

Overview

NexSens MB-300 and MB-400 data buoys are designed specifically for offshore water monitoring systems. The floating platform supports both topside and subsurface environmental monitoring sensors with options for radio, cellular, and satellite data transmission. Temperature strings, multi-parameter sondes, Doppler current meters, weather stations, and other monitoring instruments can be quickly deployed in reservoirs, lakes, rivers, streams, and protected coastal waters.

The buoys are constructed of an inner core of cross-linked polyethylene foam with a tough polymer skin. A 6" diameter pipe passes through the center of the buoy for quick deployment of subsurface instruments. On the topside, a hinge-mount aluminum tower offers quick access to instrumentation for calibration and maintenance. Three topside cutouts accommodate NexSens SP5 solar power packs, which include a 5-watt solar panel, charge regulator, and 8.5 A-Hr SLA battery housed in a watertight enclosure. Top and bottom-mounted stainless steel eyes support mooring lines and lifting rigs for quick deployment.

The 300 lb. and 400 lb. buoyancy buoys are designed to accommodate NexSens SDL500 submersible data loggers. The SDL500 is configured with five sensor ports for connection to industry-standard digital and analog sensor interfaces, including RS-485, SDI-12, 1-wire temp string, 0-2.5V, pulse count, and more. Each sensor port offers a UW receptacle with double o-ring seal for a reliable waterproof connection. NexSens iChart Software is a Windows-based program for interfacing both locally (direct-connect) and remotely (through telemetry) to a single data buoy or network of data buoys.



Figure 1: MB-300 Data buoy

Typical Configurations

There are two typical configurations for data buoy applications: single-point or two-point moorings.

Single-point Mooring

Single-point moorings are used when monitoring sensors are deployed within the buoy counterweight. The sensors are protected and less vulnerable to damage caused by subsurface debris, high currents and entanglement from anchor lines.

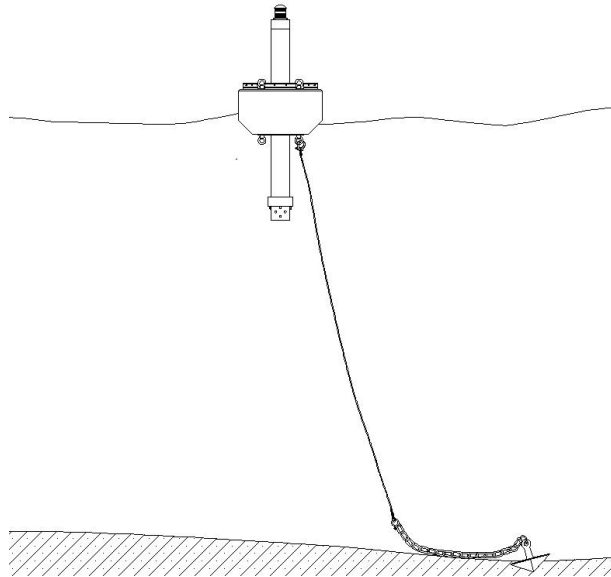

Figure 2: Data buoy deployment setup with 1-point mooring

Two-point Mooring

Two-point moorings are commonly used when monitoring sensors are deployed in the water column below the buoy. The mooring lines are pulled taut away from the data buoy, freeing the water column for a suspended sensor line.

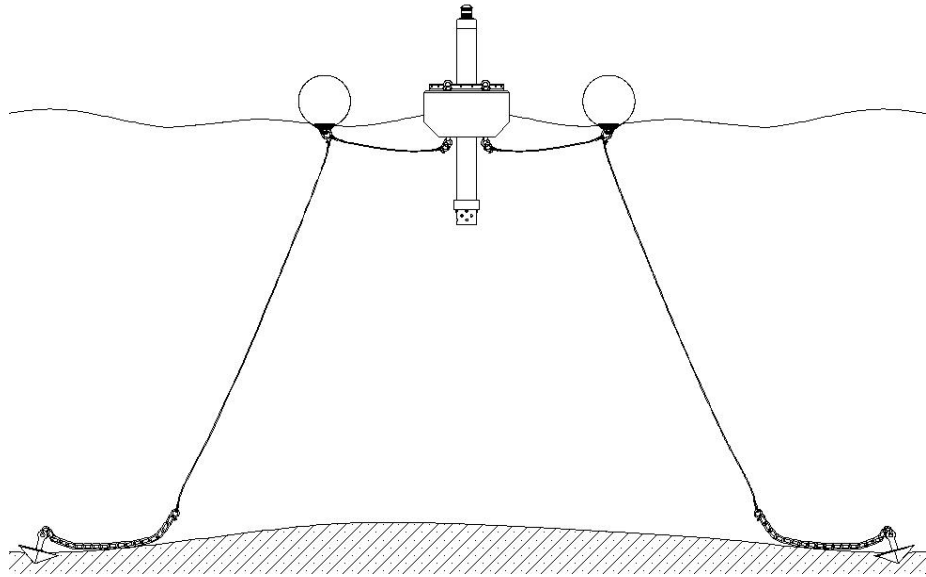

Figure 3: Data buoy deployment setup with 2-point mooring

What's Included

The MB-300 and MB-400 data buoys each include a foam hull with mooring and lifting eyes, stainless steel counterweight, and 20 lb. ballast weight.

Common Accessories

Table 1: Accessories commonly used with NexSens data buoys

Part Number	Description	Details
SDL500	Submersible data logger	Fully submersible data logger designed for use with NexSens data buoys. Telemetry options include cellular, radio, and satellite.
Tower	Aluminum buoy tower	Provides beacon mounting and deployment housing for SDL500 data logger.
502-A15	Beacon, LED	Mounts to buoy tower, 15 flashes per

WHAT'S INCLUDED

		minute.
SP5	5-Watt solar power pack	Solar power pack includes 5-watt solar panel, charge regulator, and 12 VDC, 8.5 A-Hr battery, 3 suggested.
SP5-PH	Solar power harness	Used to connect up to three SP5 solar power packs to an SDL500.
BAL20	Ballast weight, 20 lb.	Additional ballast weight for especially rough deployment conditions.
DOR35	Anchor	Pyramid anchor, 35 lb.
DOR70	Anchor	Pyramid anchor, 70 lb.
SSPA375-BOW	Shackle	Bow shackle, $\frac{3}{8}$ "
SSPA500-BOW	Shackle	Bow shackle, $\frac{1}{2}$ "
SSPA625-BOW	Shackle	Bow shackle, $\frac{5}{8}$ "
SS187	Stainless steel mooring line	Used for buoy and sensor mooring systems.
HGPC500i	Chain, $\frac{1}{2}$ "	Galvanized steel chain used for buoy moorings.
PLM-NB60R	Marker buoy, 18" diameter	Used for 2-point buoy mooring systems.
T-Bumper	Cable bumper	Used to prevent sensor cable chafing during deployment.

Specifications

Table 2: NexSens data buoy specifications

<p>Dimensions</p>	<p>Tower: 6" diameter, 25.2" height (with lid) Counterweight: 6" diameter, 36" height Hull <i>MB-300:</i> 29.5" diameter, 16" height <i>MB-400:</i> 29.5" diameter, 20" height Overall <i>MB-300:</i> 77.2" height <i>MB-400:</i> 81.2" height</p>
<p>Weight</p>	<p><i>MB-300</i> 97 lbs (with ballast and tower) 149 lbs (with solar and SDL500) <i>MB-400</i> 106 lbs (with ballast and tower) 158 lbs (with solar and SDL500)</p>
<p>Materials</p>	<p>Hull: cross linked polyethylene foam with polymer skin Tower: 6061 aluminum Counterweight: 304 stainless steel</p>
<p>Maximum Buoyancy</p>	<p>300 lbs, 400 lbs, respectively</p>
<p>Mooring Attachments</p>	<p>(6) ¾" stainless steel eye nuts, (3) top-mounted and (3) bottom-mounted</p>
<p>Suitable Environments</p>	<p>Freshwater lakes, rivers, streams, protected coastal waters, and small reservoirs</p>
<p>Beacon</p>	<p>LED with solar power, 15 flashes per minute, amber</p>
<p>Power</p>	<p>SP5 solar packs include a 5-watt solar panel, charge regulator, and 8.5 A-Hr 12 VDC battery</p>

Getting Started

NexSens data buoys should be fully constructed on shore prior to deployment. Common accessories such as the tower, solar panels and additional ballast weight require user assembly.

Tower Assembly

Secure the buoy in an upright position. Keep the top of the buoy open and free for mounting accessories.



Figure 4: Pre-assembled MB-300 data buoy

NOTE

Do not over tighten the hinge bolt. This could result in deformation to the hinge base making it difficult to open and close the buoy tower

Mount the buoy tower using the supplied $\frac{1}{2}$ " hardware (screw, lock washer, and nut) as shown. Tighten until the lock washer is flat. Avoid over-tightening.



Figure 5: Bolted connection between buoy and tower

The tower is now hinged. When vertical, the tie-down bolts align with threaded holes on the buoy top plate.

WARNING

The solar packs are made of glass and will break. Avoid dropping tools and impact with other objects.



Figure 6: Tie down bolts are tightened to keep buoy tower from hinging back

Solar Power Pack Assembly

There are three cut-outs in the buoy for the solar packs. Insert each solar pack into a cut-out.



Figure 7: SP5 solar power pack installation

Position the output power cords (MS4 pin connector) over the center buoy well (as shown). These will be connected later to the harness that supplies power to the SDL500 data logger.

NOTE

Be sure to keep the MS4 pin connectors dry and protected when not connected.



Figure 8: SP5 power packs MS4 connector positioning

Use the supplied screws ($\frac{5}{16}$ "-18 x $\frac{1}{2}$ "), washers, and lock washers to secure the solar packs to the top of the buoy. Be sure to tighten until the lock washers are flat.



Figure 9: 5/16" hardware is used to fasten the solar power packs to the buoy top plate

Loosen the tie-down bolts and confirm that the buoy tower opens and closes without hitting the solar panel.

Beacon Assembly

NOTE

Do not over tighten the beacon mounting screws. The beacon deforms easily under screw loading.

The top lid of the buoy tower includes the hardware necessary for mounting a beacon. Remove the screws, and position the beacon as shown. Use the supplied screws ($\frac{1}{4}$ "-20 x $1 \frac{1}{4}$ "), lock washers, and washers to secure the beacon in place.



Figure 10: 1/4" hardware is used to fasten the beacon to the buoy tower lid
Use the supplied screws ($\frac{1}{4}$ "-20 x $\frac{3}{8}$ "") to mount the buoy lid with beacon to the top of the tower.



Figure 11: 1/4" hardware and 3/16" Allen wrench are used to tighten the buoy tower lid to the tower

Pre-deployment Test

Prior to deployment, it is essential to test the monitoring system (sensors, data logger, and telemetry) on shore. This will allow users to familiarize themselves with the system and confirm proper operation.

Install and Power the Data Logger

Open the tower to the horizontal position and remove the two stop bolts near the bottom. This will allow the SDL500 to be inserted.

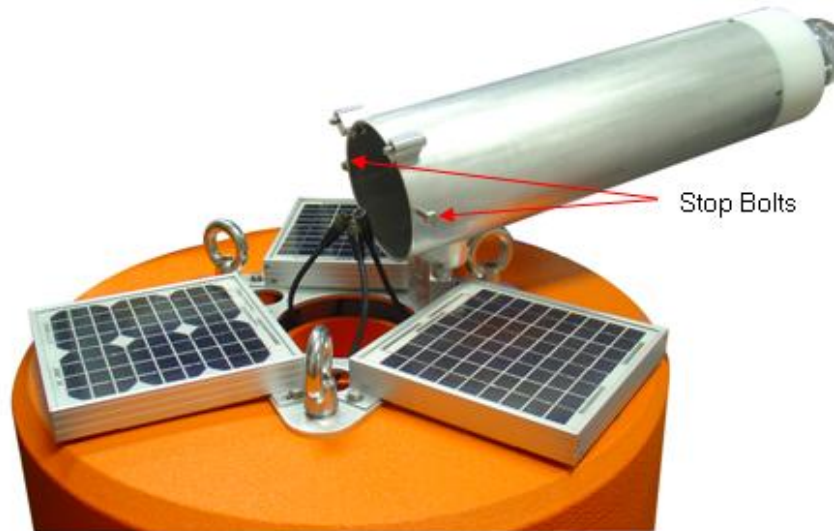

Figure 12: Stop bolts backed out to allow SDL500 access into tower

Position the SDL500 partially out of the tower and remove the bottom guard.



Figure 13: SDL500 positioned partially out of tower

Connect the power harness to port D and attach each of the MS4 connectors to the mating solar pack connectors (now

located in the center buoy well). Be sure the guard is installed in-line, as it will be reconnected later.



Figure 14: SDL500 positioned slightly out of tower with guard removed and power harness connect to port D

Connect Sensors

Connect sensors to the appropriate ports on the SDL500. Refer to the SDL500 operations manual for additional information.



Figure 15: SDL500 positioned slightly out of tower with sensors connected
Reconnect the guard to the SDL500 data logger.

WARNING

Buoy motion caused by wave action can quickly chafe sensor cables. A cable bumper must be used for 2-point mooring applications.



Figure 16: SDL500 positioned slightly out of tower with connections made to sensor bulkhead and guard re-installed

The tower will remain open during this pre-deployment check, so sensor cables can simply hang over the side of the buoy.

Confirm Data Collection & Transmission

Launch iChart software and confirm that the SDL500 and sensors are communicating properly. Refer to the appropriate data logger manual and iChart software manual for additional information as required.

The pre-deployment check is complete. The buoy, data logger, and sensors can now be prepared for deployment.

Prepare for Deployment

The buoy will initially be deployed (moored in the water) without the data logger and sensors in place. Disconnect the MS4 power connectors and pull the SDL500 and sensors from the tower.

Insert the tower stop bolts and return the tower to the vertical position. Tighten the tie down bolts.

Setup the Sensor Mooring Line

Connect the buoy attachment chain to the top of the mooring line using the $\frac{3}{8}$ " bow shackle. The opposite end of the chain will be connected to a top side mooring eye.

Connect the heavy chain to the bottom of the sensor mooring line using $\frac{1}{2}$ " bow shackle.

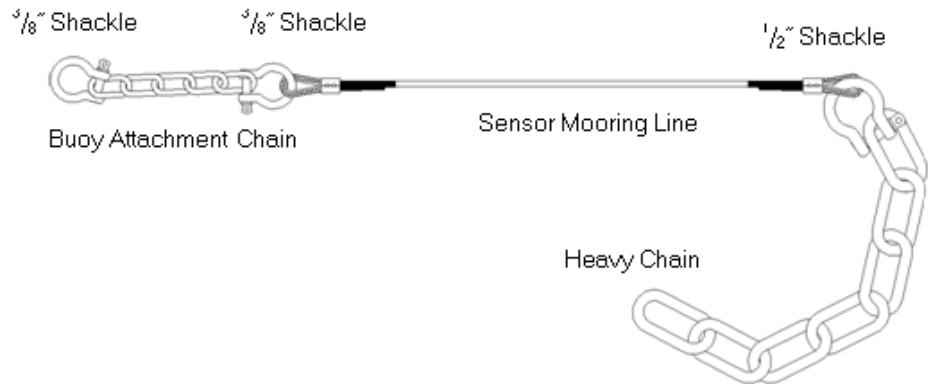

Figure 17: Typical sensor mooring line assembly used with NexSens data buoys

With the SDL500 data logger and sensors laid out on a flat surface, secure to the sensor mooring line using sensor clamps and plastic cable ties.

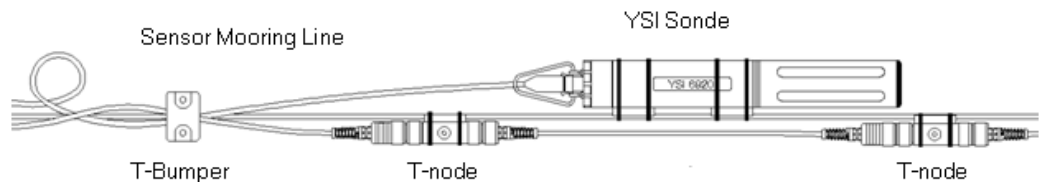

Figure 18: Sensor mooring line with T-Node temperature sensors and YSI water quality sonde

WARNING

Buoy motion caused by wave action can quickly chafe sensor cables. A cable bumper must be used.

To prevent cable chafing, it is recommended that a cable bumper (T-Bumper) be used to separate the sensor cable from the sides of the counterweight. Position the bumper so that it will fit just inside the bottom of the counterweight (see drawing below).

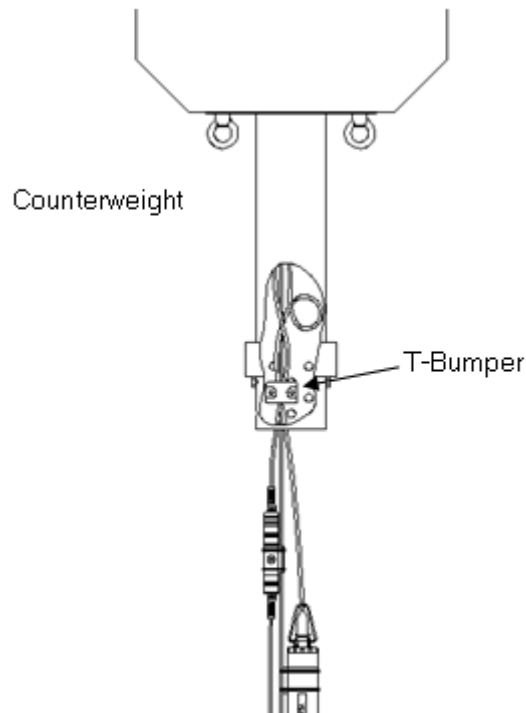

Figure 19: T-Bumper in deployment pipe used to minimize cable chafing

With the SDL500 data logger and sensors properly attached to the sensor mooring line, the system is now ready to be lifted onto the work boat for deployment. Coil the sensor mooring assembly for convenient transport.

Safely Deploy the Buoy

Personnel safety should be the number one priority when deploying the buoy. Follow these steps closely to ensure safe deployment.

A two-point mooring offers the best solution for applications where sensors are suspended below the buoy. The two moorings separate the buoy mooring lines from the sensor mooring and help prevent entanglement and cable chafing.

WARNING

Proper safety and flotation gear should be worn at all times when working on or near the water.

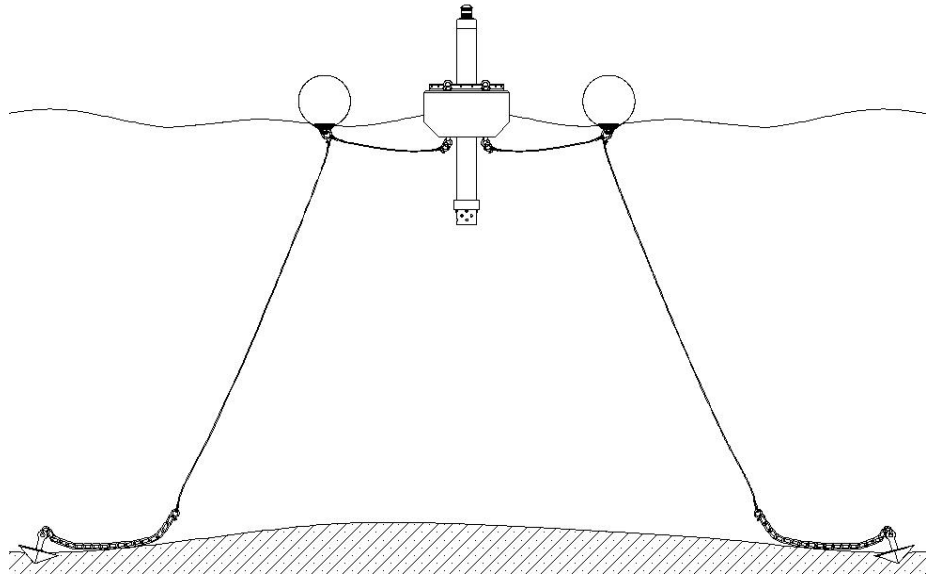

Figure 20: Data buoy deployment setup with 2-point mooring

Prepare Buoy & Anchor Lines

Connect a short stainless steel line to the marker buoy using a $\frac{5}{8}$ " shackle with screw pin through the thimble (see below).

Attach a $\frac{1}{2}$ " shackle to the opposite end of the line.

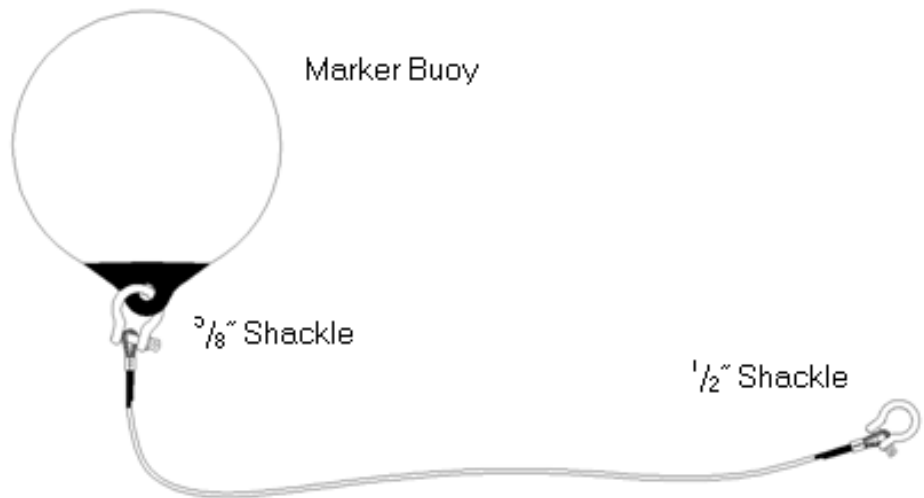

Figure 21: Typical marker buoy line connected to NexSens data buoy

NOTE

The water column line should be shorter than the approximate depth of the water column. Bottom chain allows for fluctuations in water level.

Connect the anchor, bottom chain, and water column line using one 1/2" shackle and one 5/8" shackle (see below).

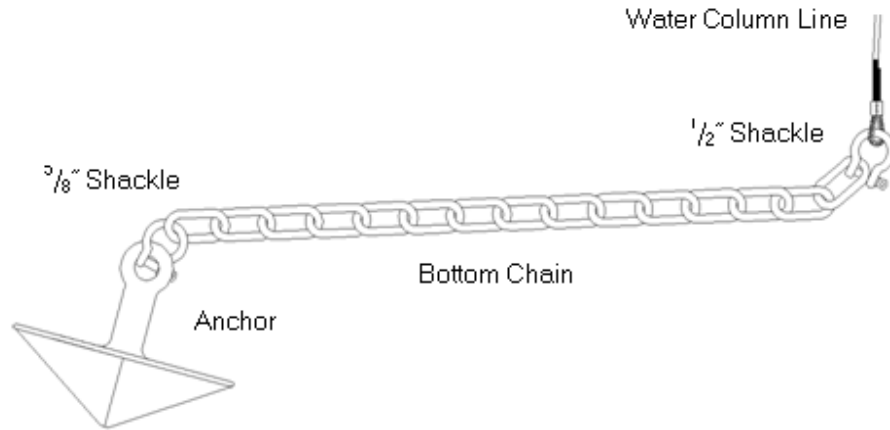

Figure 22: Typical anchor line connected to marker buoy

Attach Buoy & Anchor Lines

Before deployment, attach the buoy lines to two of the bottom side mooring eyes. DO NOT attach anchors, chain, and long mooring lines.

WARNING

For personal safety, it is essential to use the proper equipment (work boat, lifting rig, etc.) to deploy any data buoy system.

The buoy systems are heavy and personnel can quickly become entangled with mooring lines and anchors.

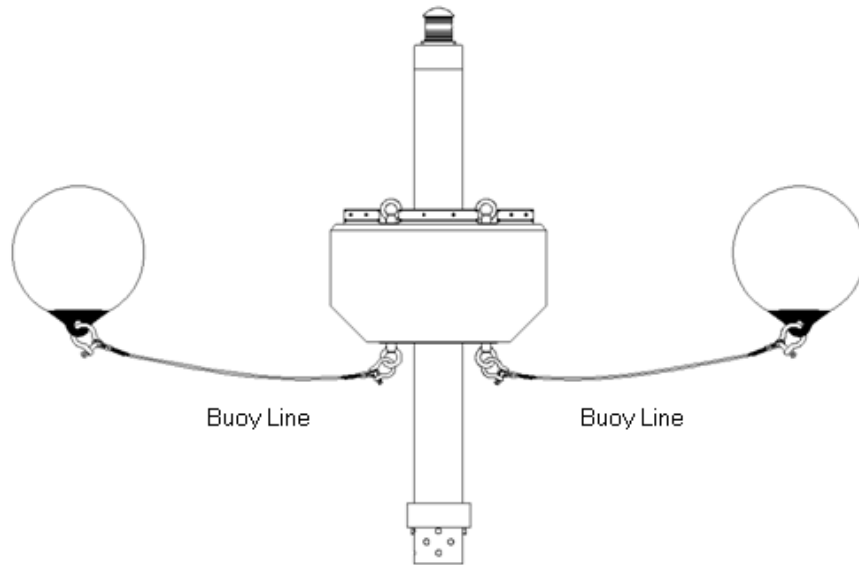

Figure 23: Data buoy shown with buoy lines attached to bottom mooring eyes

Place the buoy in the water and allow the two marker buoy lines to follow. The data buoy and two marker buoys are now floating clear of the boat.

Attach the closest marker buoy to the anchor line as shown.

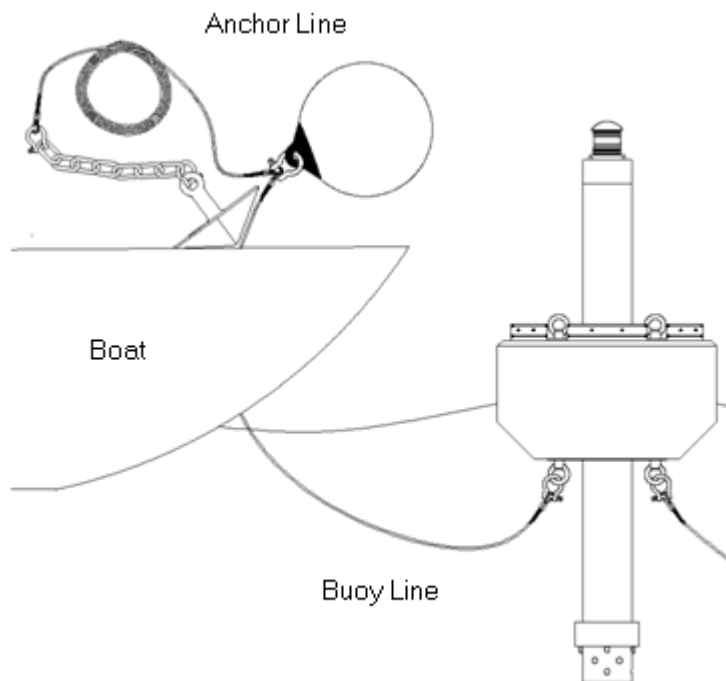

Figure 24: Anchor line connected to buoy line

With the data buoy floating in the desired location, move the boat while paying out most of the anchor line and chain. Drop the first anchor.

Move the boat to the opposite side, and attach the second marker buoy to the anchor line. Move the boat while paying out most of the anchor line and chain. Drop the second anchor. This completes the two-point mooring.

Install Data Logger & Sensors

Open the tower to horizontal position by unscrewing the tie down bolts. Remove the stop bolts shown and slide the SDL500 into position. Then replace the stop bolts and reconnect the three MS4 connectors to the solar power pack cables.

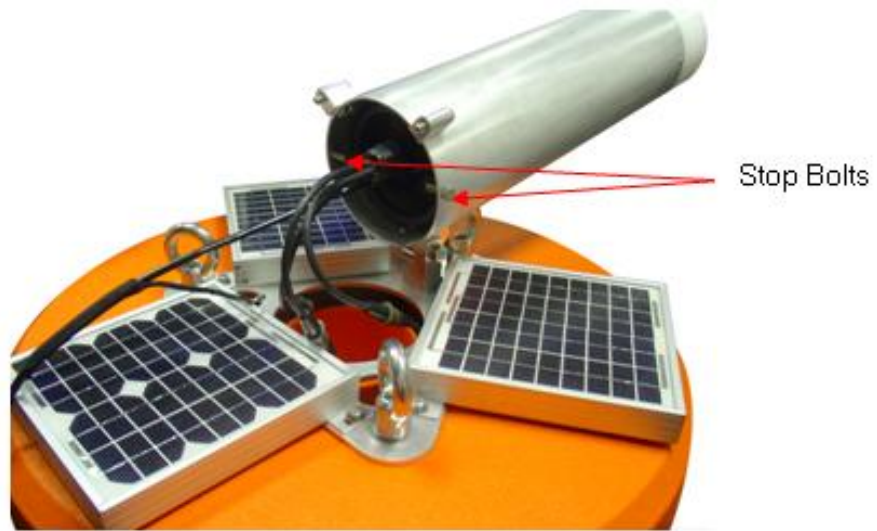

Figure 25: Tower hinged back with data logger inside

Position the connectors outside of the buoy well as shown.



Figure 26: Underwater connections positioned outside of the buoy well

Lower the sensor mooring through the center buoy well and connect the buoy attachment chain to a top side mooring eye as shown.



Figure 27: Buoy attachment chain connected to top side mooring eye

Return the tower to the vertical position and secure the tie down bolts.

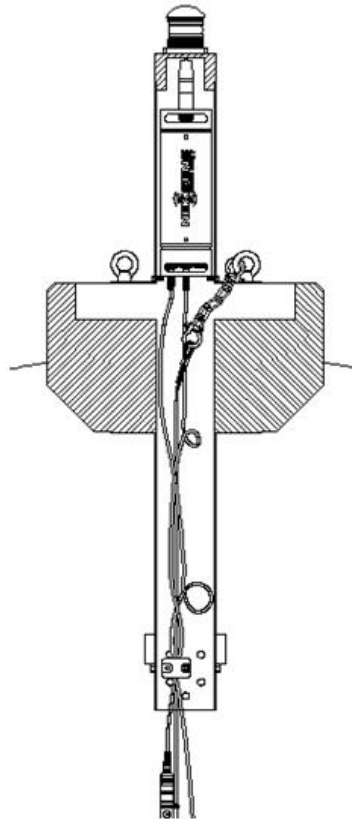

Figure 28: Complete mooring shown inside of data buoy, including buoy attachment chain connected to top side mooring eye

The data buoy is now deployed and operational.

Maintenance

NexSens data buoy systems are solar powered, and maintenance is limited to keeping the solar panels clean and periodic calibration of appropriate sensors.

Post-Season Cleaning & Storage

Before decommissioning the buoy for the season, first pull the sensor mooring (disconnecting the solar power packs from the power harness) followed by anchor and buoy lines.

Scrub all components to remove all biological fouling and store in a clean, dry location.

If possible, keep the solar panels near a window facing south. This will keep the batteries charged while not in use.

WARNING

The solar packs are made of glass and will break. Avoid dropping tools or impact with other objects.

Warranty and Service

NexSens Technology, Inc. warrants products against defects in materials or workmanship for a period of 12 months from the date of delivery to the original customer. This warranty is limited to the replacement or repair of such defects, without charge, when the product is returned to NexSens Technology, Inc. Damage due to accidents, misuse, tampering, lack of reasonable care, loss of parts, failure to perform prescribed maintenance, or accidents of nature are not covered. This warranty excludes all other warranties, express or implied, and is limited to a value not exceeding the purchase price of the instrument.

Limitation of Warranty

This warranty is not applicable to any NexSens Technology, Inc. product damage or failure caused by (i) failure to install, operate or use the product in accordance with NexSens Technology, Inc. written instructions, (ii) abuse or misuse of the product, (iii) failure to maintain the product in accordance with NexSens Technology, Inc. written instructions, (iv) any improper repairs to the product, (v) use by you of defective or improper components or parts in servicing or repairing the product, or (vi) modification of the product in any way not expressly authorized by NexSens Technology, Inc.

Corporate Headquarters and Authorized Service Center

NexSens Technology, Inc.
1415 Research Park Drive
Beavercreek, Ohio 45432
Phone 937.426.2703 • Fax 937.426.1125
E-Mail support@nexsens.com

Revision: 02 **Revision Date:** November 22, 2010

WARNING
NexSens Technology, Inc. products are not authorized for use as critical components in any life support system where failure of the product may affect its safety or effectiveness.



1415 Research Park Drive
Beavercreek, OH 45432
937-426-2703
www.NexSens.com