



1328 Parkway Court • Beavercreek • OH • 45432
Phone: (937) 426-2703 • Fax: (937) 426-1125 • E-Mail: info@NexSens.com
Visit us on the web at <http://www.NexSens.com>

**NexSens TS110-C
Temperature Profiling String
with SDI-12 Output
Sensor Interface Manual
Revision 8.1.7**

Table of Contents

Technical.....	2
Specifications.....	3
Wiring.....	4
Configuring the Controller.....	6
Updating Controller Firmware.....	15
Troubleshooting SDI-12 communication.....	17
Configurations, Options, and Accessories.....	18
Specifying TS110 Temperature Strings.....	18
Deployment Accessories.....	19
SDI-12 Commands.....	20
Temperature Calibrations.....	22

About NexSens Technology, Inc.

NexSens software and real-time data logging systems are designed to simplify the setup and operation of environmental monitoring networks. NexSens products automate much of the tedious programming, data collection, and manual data processing common with other systems.

iChart is an easy-to-learn, easy-to-use Windows-based software program designed to interface with the industry's most popular environmental monitoring sensors and systems. A large multi-vendor instrument library makes setup quick and easy. iChart automates much of the tedious programming, data collection and manual data processing common with other environmental data collection systems.

The NexSens iSIC (Intelligent Sensor Interface and Control) is a state-of-the-art line of data loggers that simplify the collection of real-time data from environmental sensors and monitoring instruments. The iSIC data logger supports multi-vendor sensor connections and is designed for environmental data monitoring with NexSens communication equipment and software.

How to Use This Manual

This manual is designed to provide you with detailed instructions for interfacing specific sensors to the NexSens iSIC data logger.

This manual provides you with all the information needed to interface your sensor with the iSIC data logger. For advanced system and sensor reference material:

- Review the material in the iSIC operations manual:
 - <http://www.nexsens.com/support/manuals.htm>
- Review the sensor manufacturer's operations manual. This information should have been provided with the purchase of the sensor. This material can also typically be found at the instrument manufacturer's website. If you are still having difficulty, email your technical support question to:
support@nexsens.com

Technical

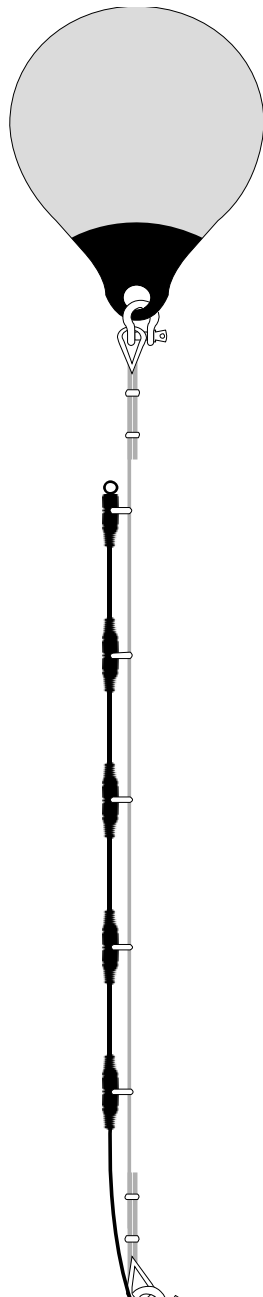

The NexSens TS110 Temperature String is a multi-point water temperature monitoring system, consisting of multiple temperature sensors spaced along a cable at user-specified intervals. The system is completed when the TS110 is connected to an iSIC data logger and operated by iChart software.

The TS110 is available for configuration with up to 120 sensors that can be spaced evenly at 1/2, 1, or 2 meters apart. The user defines the number and spacing of sensors when ordering. The total length of the string, which can be up to 200 meters, is also specified. With these options, the string is capable of taking nearly 100 water temperature readings at different depths up to 200 meters. The TS110 is built to operate in harsh conditions, such as coastal waters, rivers and stream fed reservoirs. It features a 60 second read time in fresh, brackish, or seawater.

The TS110 Temperature String can be deployed as either a bottom-deployed system or surface data buoy system.

The bottom-deployed system is used to collect water temperature data that will be stored in a data logger resting on the bottom for later retrieval. In this system, the TS110 Temperature String will be fastened to a mooring cable suspended by a mooring buoy near or on the surface. At the bottom, the mooring cable is attached to a chain and anchor, while the TS110 connects to an iSIC data logger in an underwater housing. The chain and anchor system is designed to allow for water level changes. The chain will lift off the bottom during a rise in water level.

The surface data buoy system includes a surface data buoy with integral data logger and telemetry equipment. With this setup, the TS110 is suspended directly below the buoy. Two marker buoys are connected to the sides of the surface data buoy. These marker buoys are connected via mooring cable and bottom chain to anchors on the bottom. This system is also designed to accommodate changes in water level. Contact the application engineering team at NexSens for assistance in sizing your mooring system.

Specifications

SDI-12 Compliance	v1.3
Interface	Flying lead cable
Default SDI-12 Address	0
Measuring Range	-10°C to +70°C
Accuracy	+/- 0.1°C from 0°C to 50°C +/- 0.5°C from -10°C to 0°C and from 50°C to 70°C
Resolution	12 bit, 0.0625°C
Power Requirements	10.7 V to 16 VDC 20mA during reading +1.5mA per element during measurement +3mA per element during standby

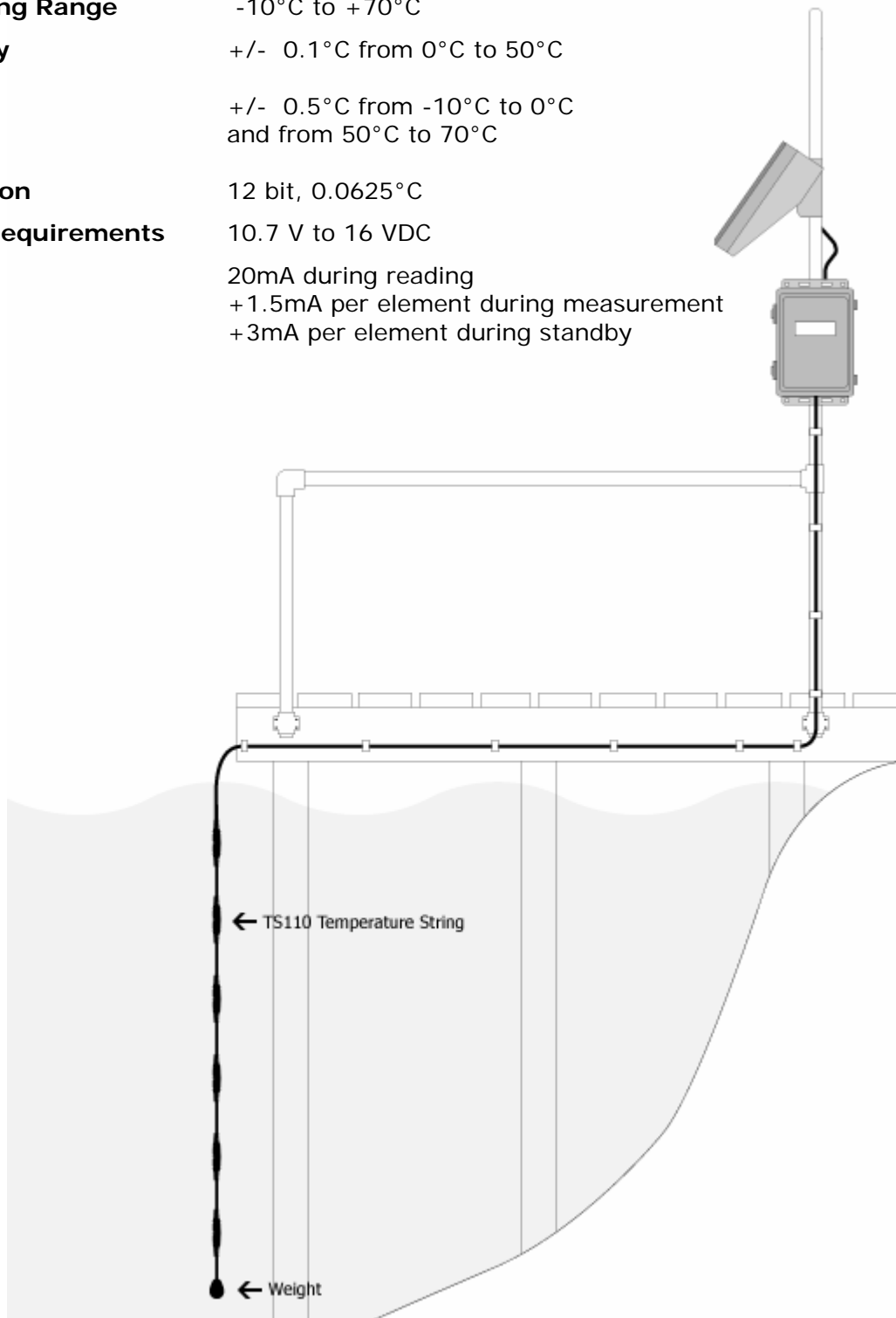

Wiring

To output temperature string data in SDI-12 format, three devices are required:

- TS110 SDI-12 controller
- TS110 temperature string
- Data logger to log SDI-12 readings

To connect the TS110 controller to the data logger used to log the TS110 data, wire the SDI-12, +12V (10.7 to 16VDC), and GND signals from the data logger to the digital terminal string of the TS110 controller.

Two sealcon fittings come with every TS110 controller. Remove one of the enclosure plugs and secure a sealcon fitting in its place to bring the SDI-12 cable into the controller box.

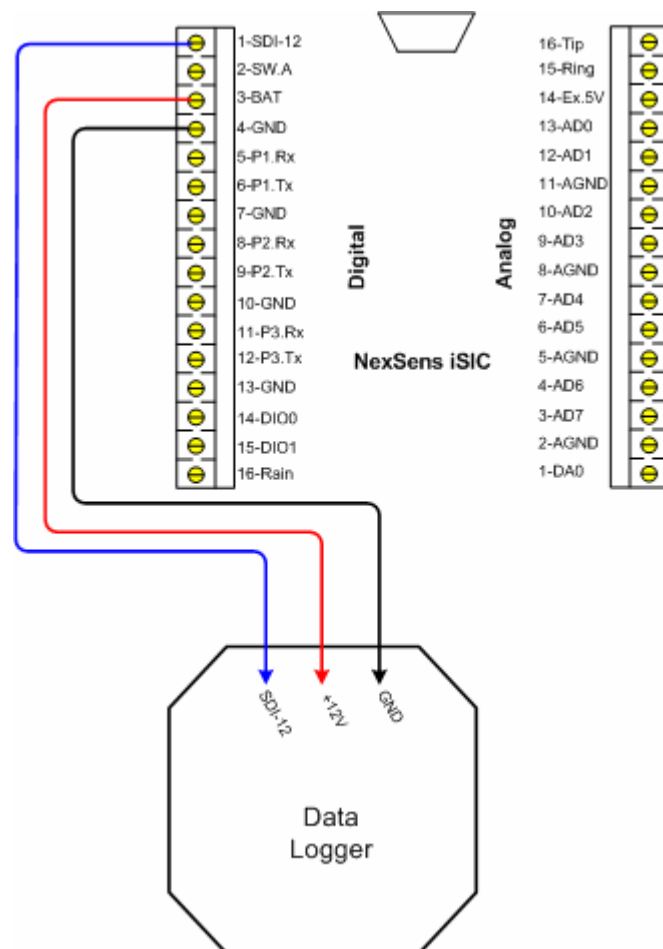

The TS110 temperature string comes with a weatherproof, MS-8 connector with housing that contains interface circuitry to the TS110 controller. This connector is not meant to be submerged for extended periods of time. Simply plug the connector to the MS-8 connector at the bottom of the controller housing. The MS8 connector on the controller contains all the power and interface signals to the TS110 temperature string.



MS8 Pin	Signal
A	DTR & RTS (+12V signal)
B	Ground
C	Rx (Input Temperature String)
D	Tx (Input Temperature String)
H	+5V

Configuring the Controller

Before the controller can be used to output SDI-12 data from the TS110 temperature string it must first be setup with the specific TS110 connected to it. **If the TS110-C controller and TS110 TempString are ordered together, the controller has already been factory configured. Please skip this section if this is the case.**

Step 1 – iChart and Sensor connection

After the TS110 has been connected to the controller and the controller powered, it is ready to be configured by iChart software. An iChart CD should have come with the controller or a 30 day trial version is available for download at:

<http://www.nexsens.com/support/downloads.htm>

Connect the controller to a COM port on your computer using an RS232 cable (Note: an A72 – *iSIC programming cable* is supplied with the controller).



Run iChart software and select “Open Without Project”

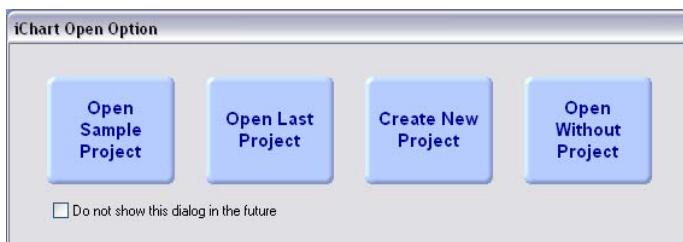

Then select **File | New Project**.

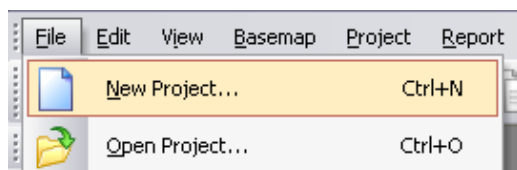

Enter a project name and click **Save**.

Setup Device Wizard

The Setup Device Wizard will begin. Click **Next** to continue.

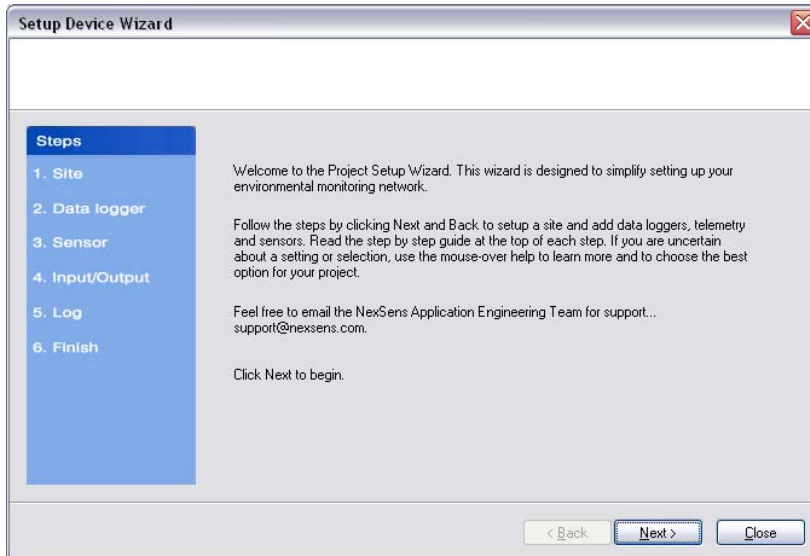

Step 1 – Site Setup

The first step is to create a site for data loggers and sensors to be located in. If this is an existing project, sites may already exist. Enter a **Site Name** and click **Add**.



Step 2 – Data Logger & Telemetry

The next step is to add the data logger(s) to the sites created in the previous step. Select a site to add a data logger to. Then select **iSIC** from the data logger model number from the list at right and click **Add**.

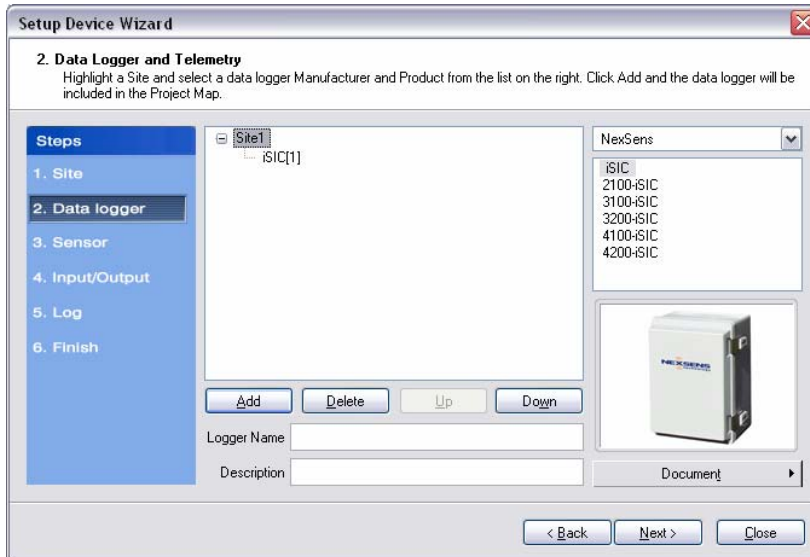

The **iSIC Data Logger Communication Properties** dialog box will appear. Enter the iSIC address and select the PC COM Port that the data logger is connected to.

- The iSIC address is default '1'. If unknown, enter '0' and click **Test Connection** to determine the address. Note: this address is different than the SDI-12 address of the controller.
- The PC COM Port drop-down menu is the list of available COM ports iChart detected on the computer.

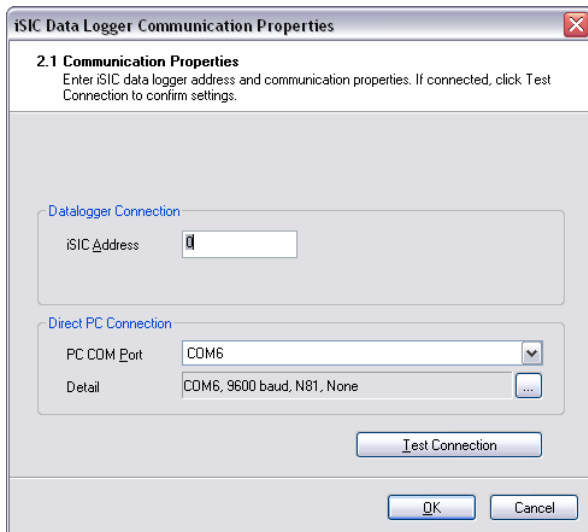

Step 3 – Sensor

After selecting a data logger, click **Next** and select **NexSens** from the drop-down list of manufacturers. Then select the **TS110** model number and click **Add**.

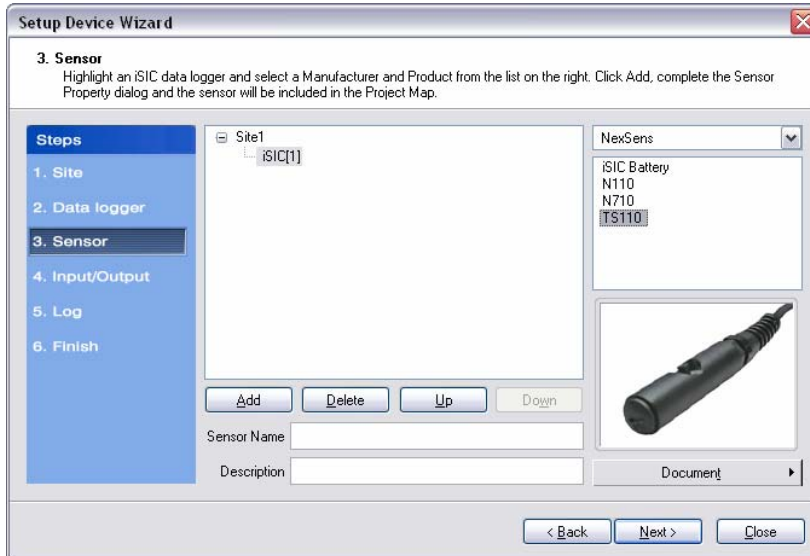

The **Sensor Properties** dialog box will come on the screen.

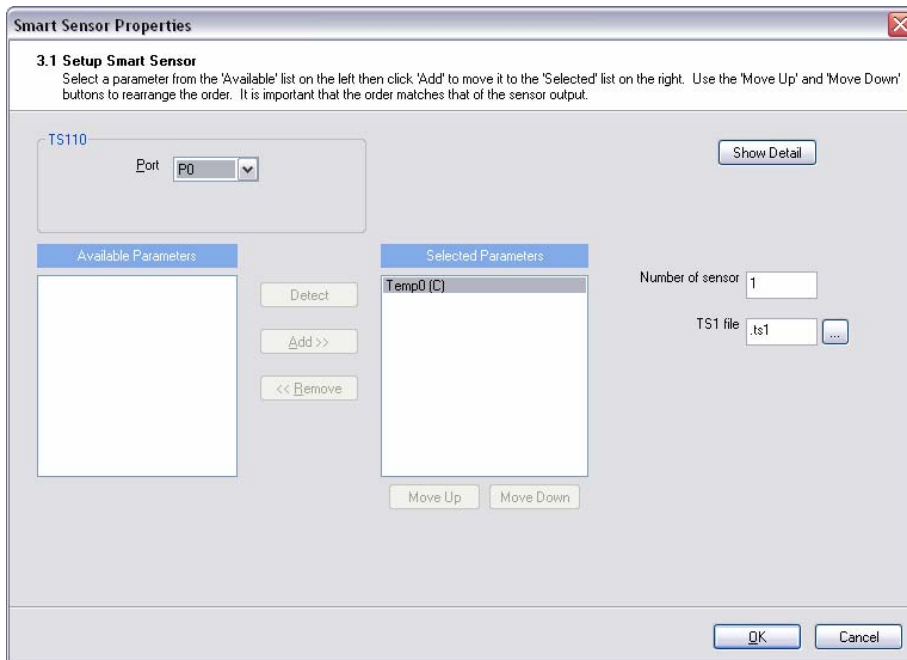

Click on the '...' next to the TS1 file text box.

This will open the **TS110 Profile File** dialog box. This file is located on the TS110 profile CD that came with your TS110 temperature string. If you can no longer have the CD or are otherwise unable to find the ts1 file, contact NexSens for the original file.

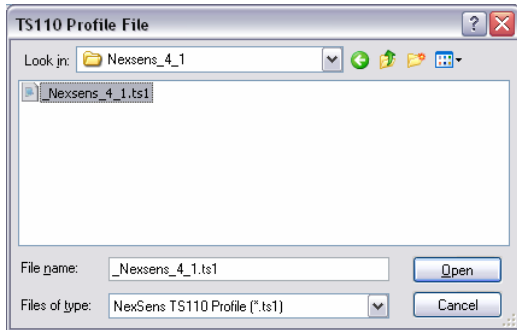

This file calibrates the sensor readings as well as provides the sensor order for the software. This file is required for proper operation. See “Temperate Calibrations” section for more information.

After clicking open, iChart will adjust the number of temperature readings on the **Available Parameters** to match the ts1 file.

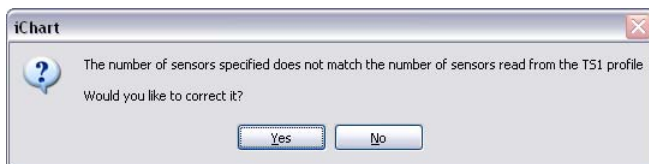

Click **Yes** to continue.

Back on the main screen, click **OK** and the sensor will be added to the selected data logger. More sensors can be added at this time by selecting the sensor manufacturer and then sensor model number from the drop down menu on the right. Click **Next** when finished adding sensors.

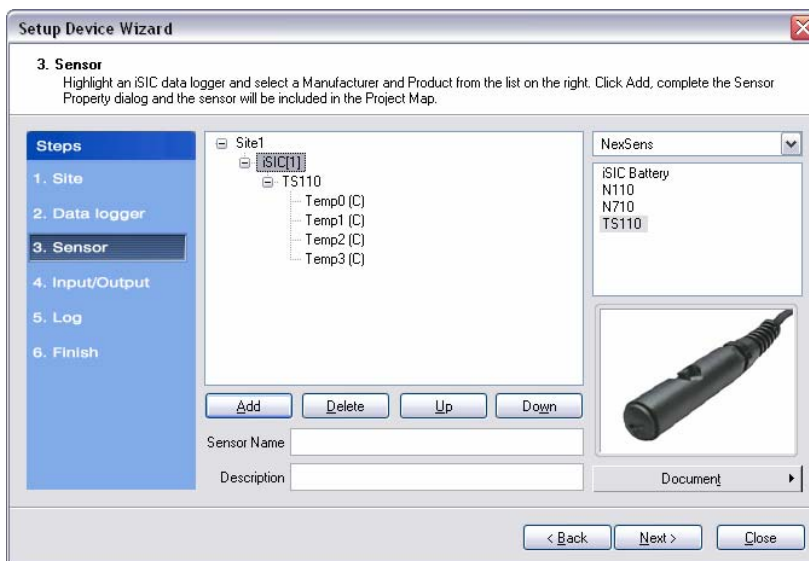

Step 4 – Input/Output

No input or output controls are functional in SDI-12 mode. Click **Next** to continue. See the iSIC manual, section **4.4.2 iSIC Controls** for more information on this functionality.

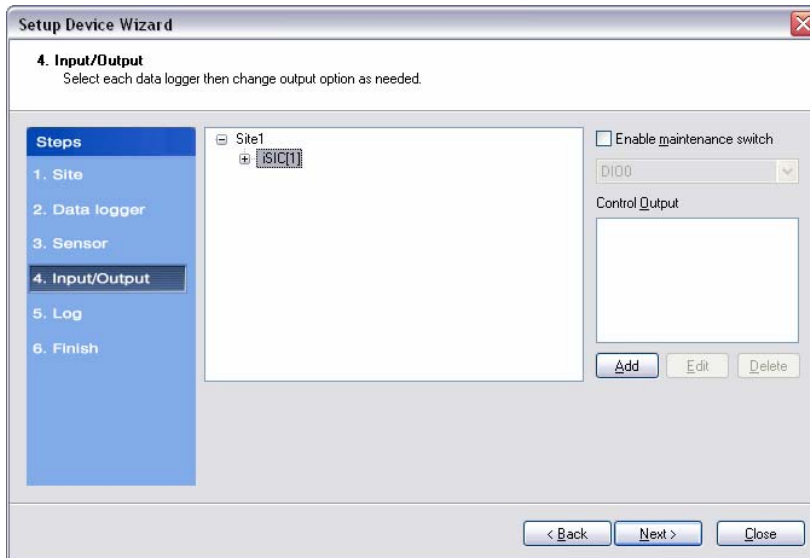

Step 5 – Log

It is recommended that a 1 minute sample and log interval is selected when setting up a data logger for SDI-12 for testing purposes. This allows you to make sure you are receiving good readings from the sensors after a few minutes in the lab.

After receiving a few readings, the data logger should be set to a 0 minute log and sample interval.

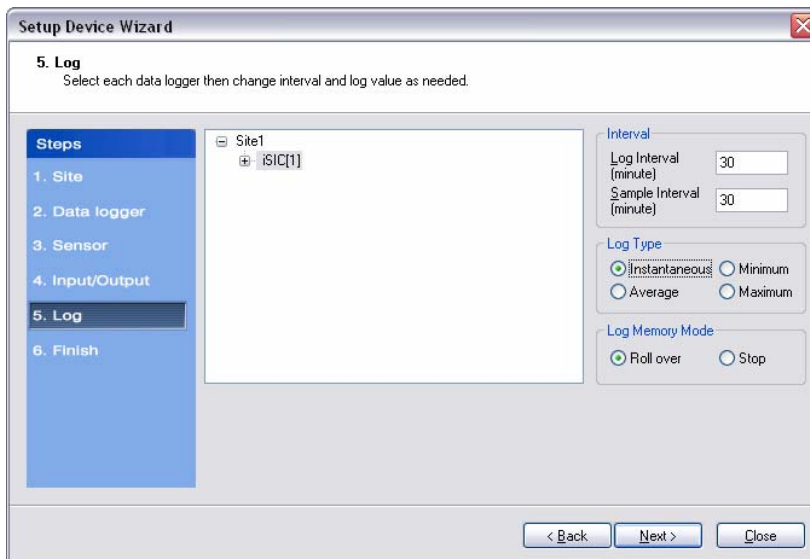

Step 6 – Finish

All data loggers and sensors must be programmed before data collection can begin.

- Select an iSIC data logger and click the '**Program iSIC**' button. Before programming an iSIC:
 - The iSIC must be powered and connected to the computer.
 - The TS110 must be connected to the MS8 connector of the iSIC.
- Click **Finish** when programming is complete.

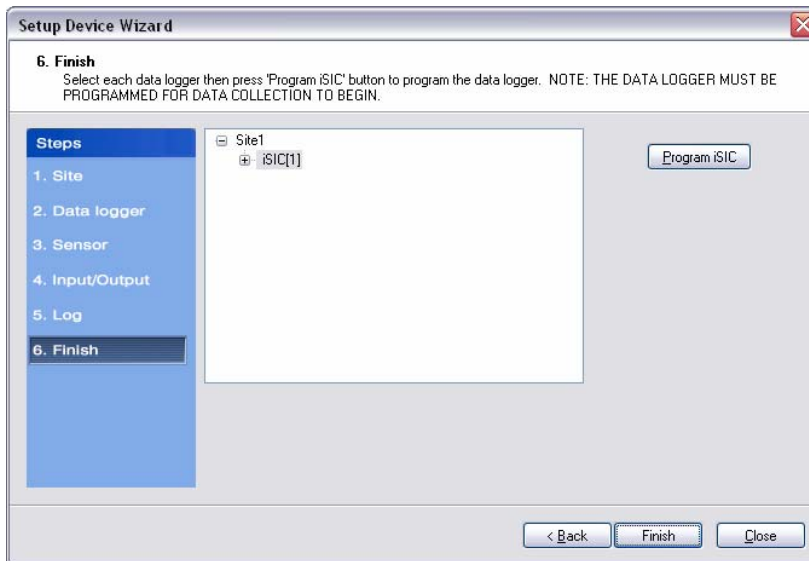

This wizard can always be revisited by selecting **Project | Setup Device Wizard** if you would like to program an iSIC at a later time or need to setup other sites, data loggers, and sensors.

Step 7 – Retrieve an Initial Data Set and Use the Instrument Within iChart

After your sensor has been added to the database, the main instrument control screen will appear.

Important: All parameters are initially displayed with blank values until after the first log interval has passed and data has been interrogated. Once data has been retrieved from the iSIC, these fields will show the most recent data set recorded by the instrument. By default, iChart will automatically interrogate devices five minutes after every hour.

After receiving a few readings, the data logger should be set to a 0 minute log and sample interval. This can be done by:

- **Select "Project | Setup Device Wizard"**
- **Click Next until the Log tab.**
- **Enter 0 for both sample and log**
- **Click Next and then Program iSIC**
- **Click Finish when complete**

After readings have been verified and the controller has been set to a 0 minute sample and log interval, it can now be switched into SDI-12 output mode.

Connect directly to the controller DB9 connector and run iChart. Select **Advanced | iSIC | iSIC** from the iChart menu.

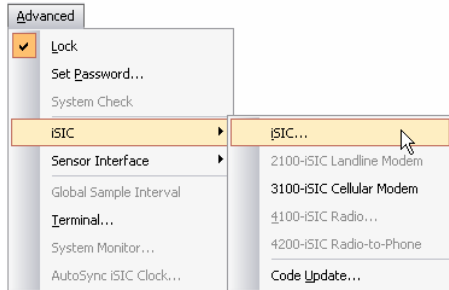

The **iSIC Setup** dialog box will appear.

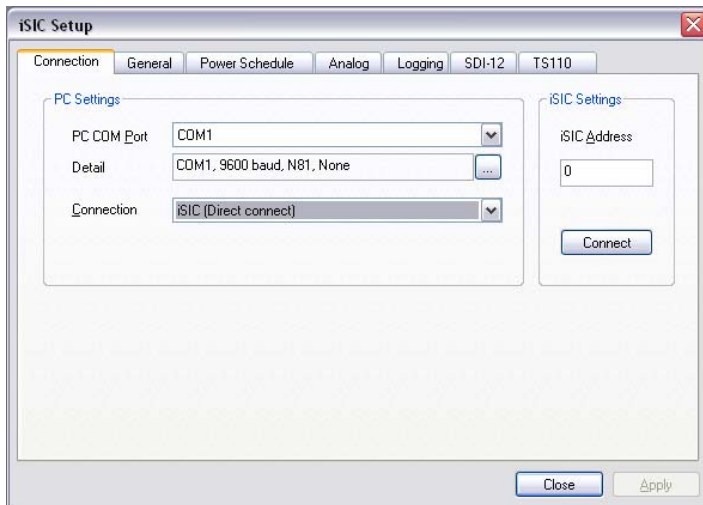

Check to make sure the **COM Port** field has selected the correct COM port the direct connect cable is attached to. If it is not, click on the **Change COM Port, Baud...** button and select the correct COM port from the menu. By default the iSIC Data logger will use 9600 baud, N81 (No parity, 8 data bits, 1 stop bit). The address can be left as **0** and the connection should be set to **Direct connect**.

Next, click **Connect** and go to the general tab.

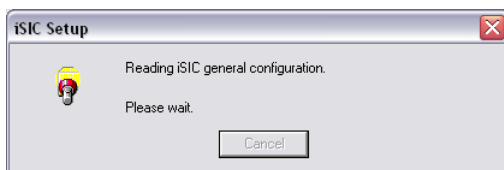

iChart will read the current configuration settings of the iSIC. This will take a few seconds. After the above screen goes away, if there are all ??? on the bottom of the general tab, hit **Close**. Then simply reset power to the iSIC (by removing power and then reapplying it) and try again. Also double check to make sure you have selected the right COM port and communication settings.

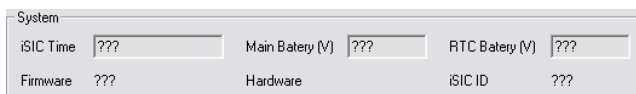

After iChart has successfully read the status information, it will be displayed on the bottom of the screen

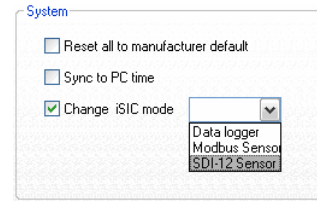
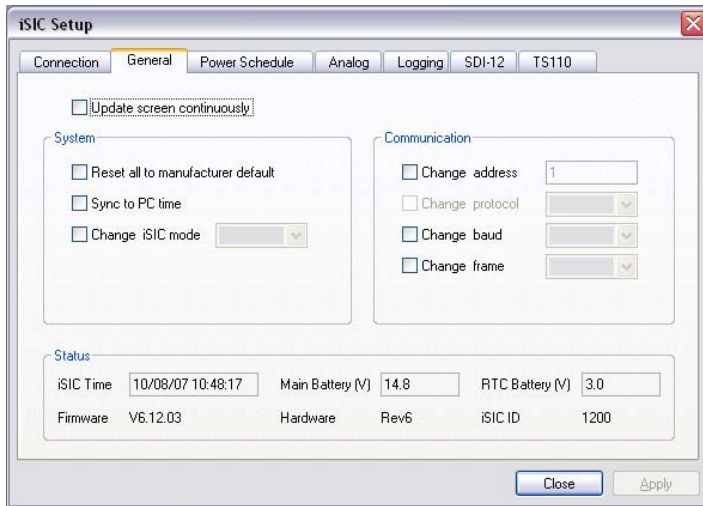

Here you will be able to setup the iSIC for SDI-12 output. Place a check mark next to **Change iSIC mode**, select **SDI-12 Sensor** and click **Apply**.

5. After obtaining the latest software, you can then perform a code update on an iSIC data logger. Select **Advanced | iSIC | Code Update** to open the **Code Update**

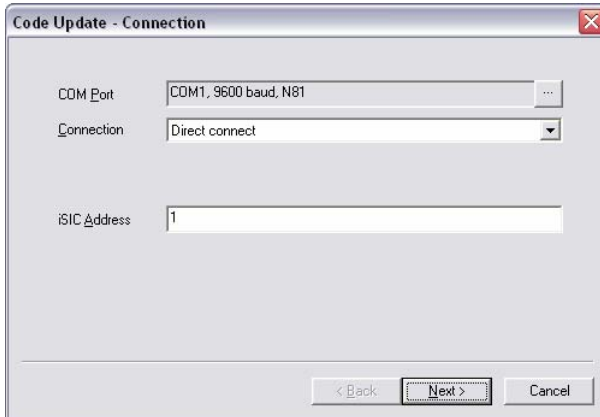

6. Select **Direct Connect** as the connection type and address 1 as the iSIC address. (Note: this address is different than the SDI-12 address used by the controller).

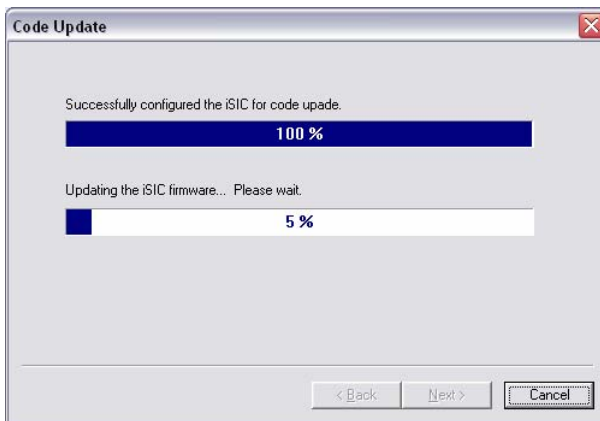

7. When iChart is finished updating the iSIC firmware, click **Done** and switch the controller back to SDI-12 mode of operation.

Troubleshooting SDI-12 communication

If at some point the controller no longer responds to SDI-12 commands there a few steps to follow to troubleshoot the connection:

1. First, make sure the SDI-12 address being used by the data logger to communicate with the TS110 controller is correct.
2. Disconnect any other SDI-12 sensors from the data logger and try communicating with the TS110 controller.
3. Next cycle the iSIC by disconnecting the digital green terminal strip inside of the controller enclosure for a few seconds and then reconnecting it. After cycling the power wait a few moments for the iSIC to restart and iChart to connect to it. You should see a green flashing light in the LED hole.



4. If no light flashes after a few seconds, make sure the fuse is not blown and between 10.7 to 16V is connected to the controller.
5. If a light is seen and the controller still does not respond to SDI-12 commands after the cycling of power, follow the steps of updating firmware to see if the controller can be directly connected to.

Configurations, Options, and Accessories

Specifying TS110 Temperature Strings

The NexSens TS110 Temperature String is a configured-to-order product. There are unlimited options for the number of sensors, spacing, and interface configurations. For quick delivery, NexSens recommends selecting from the below chart:

TS110 – N – S – L	
N = number of sensors	0...120
S = spacing between sensors	½, 1, or 2 meters
L = total length of string	0...200 meters

For example, TS100 – 4 – 1 – 10:

This temperature string includes 4 sensors, evenly spaced at 1 meter, with a total length of 10 meters. The string will have a 7-meter extension cable to the first temperature sensor.

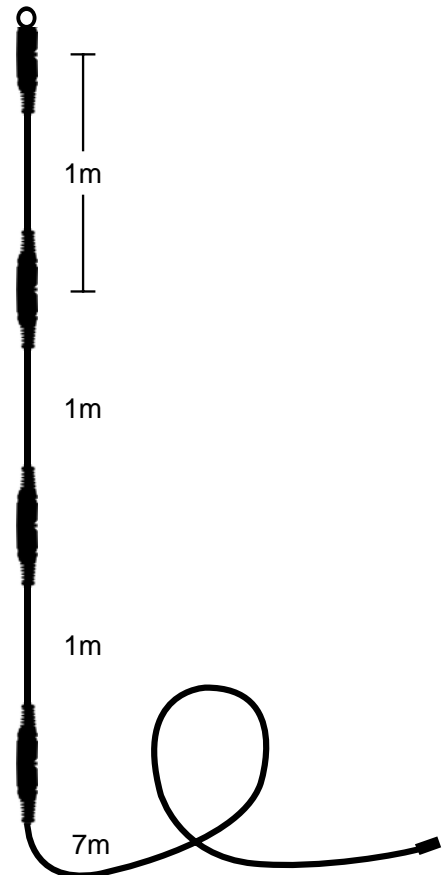

Deployment Accessories

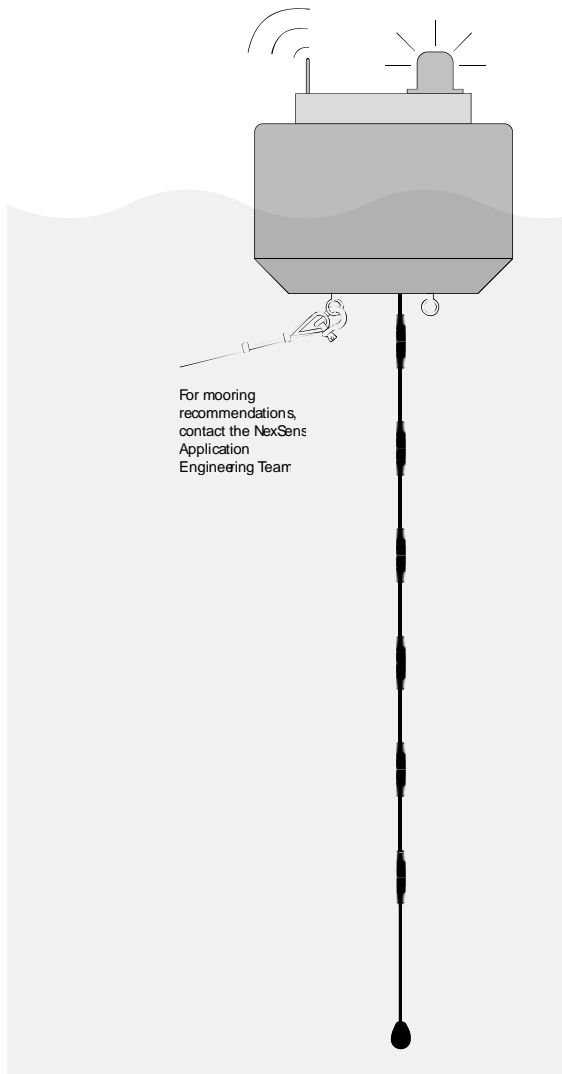

Part No.	Description
SSPA375	3/8 screw pin shackle, 316 stainless steel
SSPA500	1/2 screw pin shackle, 316 stainless steel
SSPA625	5/8 screw pin shackle, 316 stainless steel
SSPA750	3/4 screw pin shackle, 316 stainless steel
SWIV375	3/8 swivel, 316 stainless steel
SWIV500	1/2 swivel, 316 stainless steel
SWIV625	5/8 swivel, 316 stainless steel
SWIV750	3/4 swivel, 316 stainless steel
GCH375	3/8 galvanized chain
GCH500	1/2 galvanized chain
GCH625	5/8 galvanized chain
GCH750	3/4 galvanized chain
DOR15	15 lb. pyramid anchor
DOR35	30 lb. pyramid anchor
DOR70	70 lb. pyramid anchor
DOR135	135 lb. pyramid anchor
SS187-L	3/16 stainless steel mooring, line terminated with loop thimbles on each end. Specify length (L) in meters.
TS-MCLP	Mooring clamp

SDI-12 Commands

SDI-12 is a form of serial data communication designed for environmental data acquisition systems such as the iSIC data logger. SDI-12 protocol is a means of transferring measurements taken by digital sensors to a data logger for data collection and storage.

Sensors that adhere to SDI-12 protocol have a subset of commands that are consistent with every other SDI-12 sensor. These commands are used to identify the instrument, start a measurement, get data, etc.

At a user specified interval (the log or sample interval), the data logger sends the measurement command to the instrument. The SDI-12 sensor will then start taking a measurement and let the data logger know when it will be done doing so. When the sensor has finished taking a measurement the data logger will ask the sensor for the data. The sensor will return its data in a data string.

0+79.5+0.008+0.988+0.92

One thing SDI-12 protocol does not do is tell the user what parameter and unit of measurement each returned value is. This information therefore has to be specified in the software. This information is stored in the data logger.

Every SDI-12 sensor has a certain number of standard SDI-12 commands. Some sensors have extended commands that are only for that particular sensor. See the sensor manufacture's manual for more information.

 **Note** The list of standard SDI-12 commands is available in the SDI-12 protocol specification which is available from the SDI-12 Support Group here:

<http://www.sdi-12.org/>

SDI-12 Command Grammar:

a – Sensor Address

The first character of every command is the controller address. Likewise, the first character of every response is the address as well. The default controller address is ASCII '0'.

Only addresses ASCII '0' through ASCII '9' are allowed.

b – New Sensor Address

The new sensor address character is used in the change address command to specify the new address the controller should switch to. ASCII '0' through ASCII '9' are valid values of the new sensor address.

? – Wildcard Address

The wildcard address of ASCII '?' may be used in the place of a sensor address. '?' can be used in place of the SDI-12 address for any SDI-12 command (NOT just the address query command).

Implementation of Controller Specific SDI-12 Commands:

Identification:

Command: "a!"
Response: "allccccccmmmmmmvvvxx<cr><lf>"

ll, the 2 digit supported SDI-12 version, ie: "13"
cccccc, the 7 digit manufacturer name, ie: "NexSens "
mmmmmm, the 6 digit model number, ie: "iSIC "
vvv, the 3 digit major and minor firmware version number, ie: "613"
xx, the two digit build firmware version number, ie: "01"

Measurement:

Command: "aM!" or "aMC!"
Response: "atttn<cr><lf>"

ttn, the 3 digit number of seconds until the requested measurement is ready
n, the single digit number of parameters returned by the measurement. 'n' is NOT limited to '0' to '9' as in the specification. It can be '0' to '-'. The number of parameter is computed by subtracting n by '0', i.e. '-' - '0' = 10 parameter, 'D' - '0' = 20 parameters, etc.

Concurrent Measurement "aC!" or "aCC!"

Responds with number of parameter nn is NOT limited to 20 as in the specification. It can be from 00 to 99.

Request Data "aD0" ... "aD9"

Responds with the maximum number of decimal places is 5. It is truncated as needed to meet the maximum of 7 character defined in the specification.

Extended Commands:

XMODE=LOGGER

Switches the controller power-up mode from "SDI-12 sensor" to "data logger". After responding to this command, the controller still stay in SDI-12 mode. It will not switch to new mode until power has been reset. Issue the XRESET command to reset to new mode immediately without cycling the power.

XRESET

Soft resets the controller

 **Note** The list of standard SDI-12 commands is available in the SDI-12 protocol specification which is available from the SDI-12 Support Group here:

<http://www.sdi-12.org/>

Temperature Calibrations

The TS110 temperature string uses temperature sensors with a bandgap-based thermal circuit. As with these kinds of digital temperature sensors, the sensor should stay stable over time. NexSens characterizes each sensor over a 0 to 50 C range, and provides each string with its characterization file on CD. This file is used to program the controller to output characterized temperature data via SDI-12.



For quality assurance, we do provide characterization services to verify the stability and accuracy of the string, and recommend, if nothing else, you verify the integrity of the readings at least once a year.

Characterization file information:

The ts1 file is used to calibrate and position the ts110 sensor locations. NexSens characterizes every sensor element and the characterization is stored on that file. When setting the sensor up in the software it will ask you for the ts1 file.

Each file contains sensor information at the top and is tab delimited.

```

_Nexsens_4_1.ts1 - Notepad
File Edit Format View Help
-----
File: _Nexsens_4_1.ts1
Sensor=<n> <a> <b> <c> <trim1> <trim2> <id>
where err = ax^2 + bx + c
n=sensor number counted from top of string (flying leads)
id=individual sensor unique id
Desc: 4-sensor-tempstring custom profile for Nexsens
-----
Revision Log:
06/1/04 - Created
-----
FileVersion=1
ProgVersion=100
NumSensor=4
Sensor=2      2.9273E-04      -3.5094E-02      2.2858E+00      470000003ED94428
Sensor=3      2.0761E-04      -2.9308E-02      2.5849E+00      440000003EDDB628
Sensor=0      2.2432E-04      -2.3457E-02      1.6240E+00      000000003E963728
Sensor=1      2.4420E-04      -3.4270E-02      4.0286E+00      E50000003EC5FF28

```